

Jamison

# RCA

## Broadcast News

Volume No. 168, June 1980



**RCA'S OUTDOOR CAMERA SHOW:  
ONE OF THE "SIGHTS AND SOUNDS" AT THE 1980 NAB**

RCA cameras survive. They survived under fire in war zones. Survived mob attacks in Iran. Earthquakes in Central America. Every day, some 2000 RCA field cameras on duty around the world survive all sorts of cruel and unusual punishment. These are a very special breed of rugged, sharpshooting cameras that let you master any ENG or EFP situation, anywhere.

We've improved the breed even more. Our newest TK-76, for example, is lighter in weight and heavier in performance than any other camera we've ever fielded. Our renowned TK-760 is better than ever, too, with new features for sharper, brighter pictures under extremely low light. With all RCA cameras, of course, comes famous RCA TechAlert service to insure their survival, to protect your investment 24 hours a day. And to keep you shooting, no matter what.

Ask your RCA Representative about our survivors. Now. RCA Broadcast Systems, Building 2-2, Camden, N.J. 08102.

# SURVIVOR.

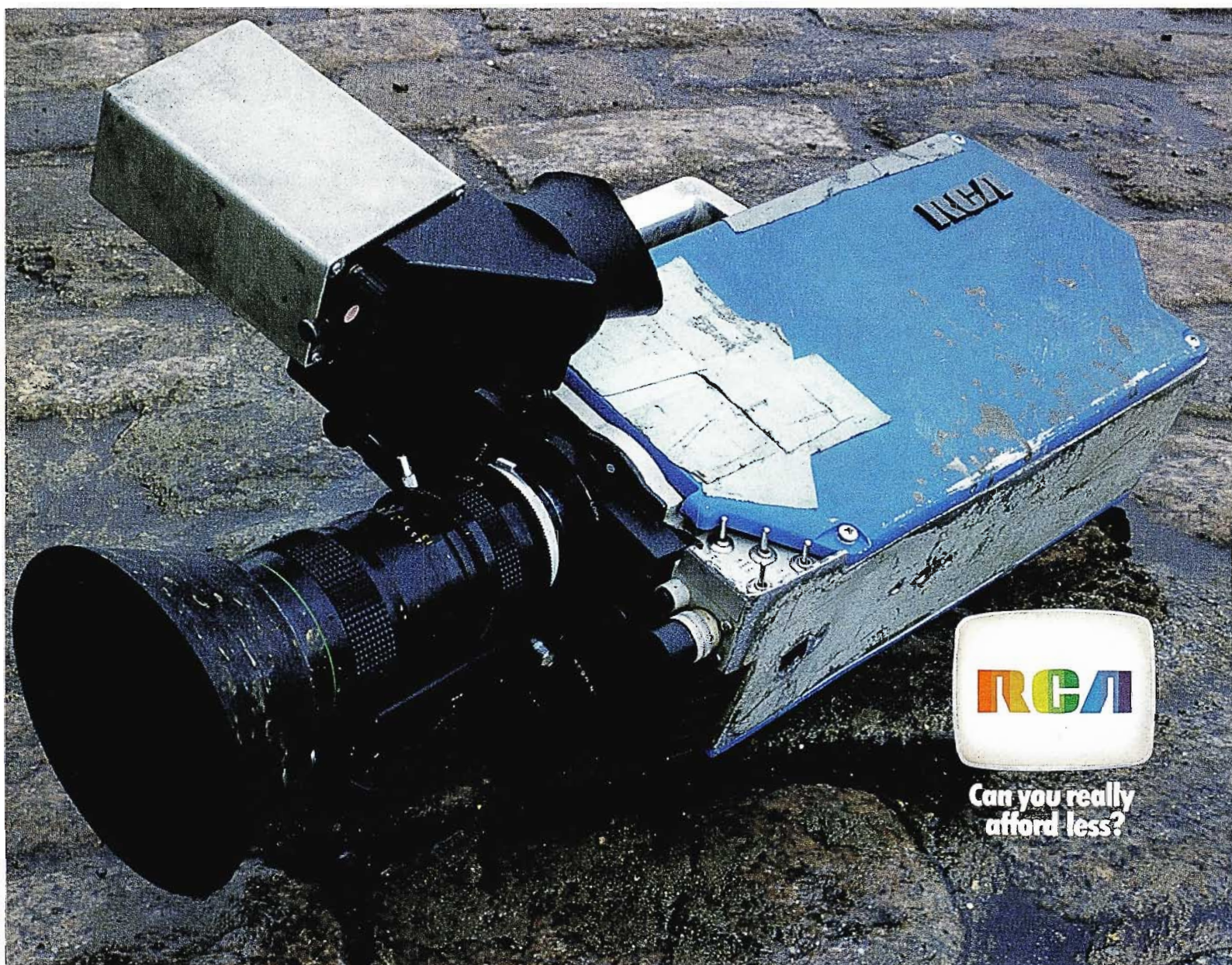



Page 6

**Accent on Technology at 1980 NAB**

"Sights and Sounds of the '80's" was the general theme for the 1980 NAB, as broadcasters and teleproducers from around the world came to see and to hear about new products and developments. The RCA exhibit was crammed with new product offerings which are covered in this overview article.



Page 17

**New Product Report: Tape; Telecine; Transmitters**

New RCA products featured here are the TR-800 one-inch Type C VTR and its full complement of system accessories, the TK-29 Series Telecine Cameras, and the BTA-5SS, solid state five kilowatt AM transmitter.



Page 23

**Cameras In The News**

This selection of photo reports from France, Germany, Korea, Australia and the U. S. typifies the worldwide utilization of RCA cameras.



Page 26

**Pacific Video's Impressive Post-Production Center**

Aesthetics and function combine beautifully in this magnificent 20,000 sq. ft. facility in Los Angeles. Its large complement of video tape recorders and sophisticated editing capability permits intermixing quad, 1-inch and 3/4-inch tape formats.



Page 34

**WITN-TV Adds Tall Tower To Keep On Top**

TV-7, serving the eastern part of North Carolina, made a \$4 million investment in a new transmitting plant complete with a 2,000' tower, circularly polarized antenna and 75 kW transmitter. Details of the new system and the results achieved are covered in this article.



Page 38

**Urban Renewal: WHEC-TV Stays Downtown**

Involved in an Urban Renewal plan, WHEC chose to rebuild in a downtown Rochester, N. Y. location right next door to its old building. Along with an efficient layout, a number of innovations are incorporated in the new facility.



Page 44

**How Saticon Tubes Improve Performance of TK-76/760 Cameras**

This technical article identifies the performance advantages of Saticon pickup tubes and details the set-up procedures for converting TK-76 and TK-760 cameras to Saticons.

# View Finder



COMMEMORATING THE 2,000TH—James A. Gimbel (left), Director, Marketing, RCA Broadcast Systems, presents to Lad Hlavaty, Vice President of Engineering-Television, RKO General Inc., a commemorative plaque in recognition of the 2,000th RCA TK-76 ENG television camera. The milestone camera, manufactured by RCA Broadcast Systems, Camden, N.J., was delivered in March to WOR-TV, New York, for use at Shea Stadium to televise the New York Mets this baseball season.

## TV Litoral Moves To Color Broadcasts With \$2 Million Purchase

Television Litoral S.A. is equipping its Rosario, Argentina TV station for the 1980 advent of color broadcasts in that country with RCA studio and transmitting systems valued at approximately \$2 million.

The new equipment being installed includes a TTG-30L 30-kilowatt transmitter, circularly polarized TV antenna and color TV studio equipment.

The new advanced-design transmitter replaces a 10-kilowatt unit now in operation, and will operate in conjunction with a model TDM-7A2 circularly polarized antenna. The TDM antenna is designed for tower top mounting, and uses a single radiator for both horizontally and vertically polarized signals.

Color TV studio systems on order for the Rosario station include two TK-760 studio/field production cameras; a TK-76 portable; a TCR-100 video tape cartridge recorder, and TR-600 quadruplex recorder, a TK-28 telecine system, and audio and control systems.

**NEW COLOR TV TRANSMITTER FOR ARGENTINA**  
—Representatives of Television Litoral S.A., Rosario, Argentina, inspect an RCA TTG-series advanced-design color television transmitter on order for the station. Left to right, Jorge Vila, Technical Director; Eng. Ernesto Daumas, Vice President, and Eng. Avelino Mendez, Director General. The new RCA transmitter will operate in conjunction with a circularly polarized TV antenna when color broadcasts begin in Argentina in 1980.

## Venevision, Caracas, Orders RCA TV Broadcast Systems Valued At Nearly \$5 Million

In a major expansion and upgrading of the program origination and transmitting facilities of its TV station network, the Corporacion Venezolana de TV (Venevision), Caracas, Venezuela, has ordered RCA broadcast equipment valued at nearly \$5 million.

The purchase includes four TTG-series VHF television transmitters, associated antennas, and video tape and telecine studio equipment.

Two TK-28 telecine islands and a TCR-100 video tape cartridge recorder will be installed in Venevision's program production and origination center in Caracas. The new TCR-100 joins a unit which has registered more than one million operations since its installation.

The new transmitters, introduced last year by RCA, will replace existing units at Venevision's stations in Maracaibo, Sabana Larga, Terepaima and in Pí-cacho.

## Chronicle Broadcasting Expands Studio Facilities

In a major upgrading and expansion of the technical facilities of its two group TV stations, Chronicle Broadcasting Company is installing RCA TV film systems, ENG cameras and video tape cartridge recorders valued at more than \$900,000.

KRON-TV, Channel 4, San Francisco, will place in operation two TCR-100 video tape cartridge recorders, equipped with RCA's automation accessory. The machines will be integrated into the station's total technical automation system. The TCR-100 provides for electronic identification and programmable random play of the video cartridges.

KRON-TV and WOWT, Channel 6, Omaha, NE, each will receive two complete

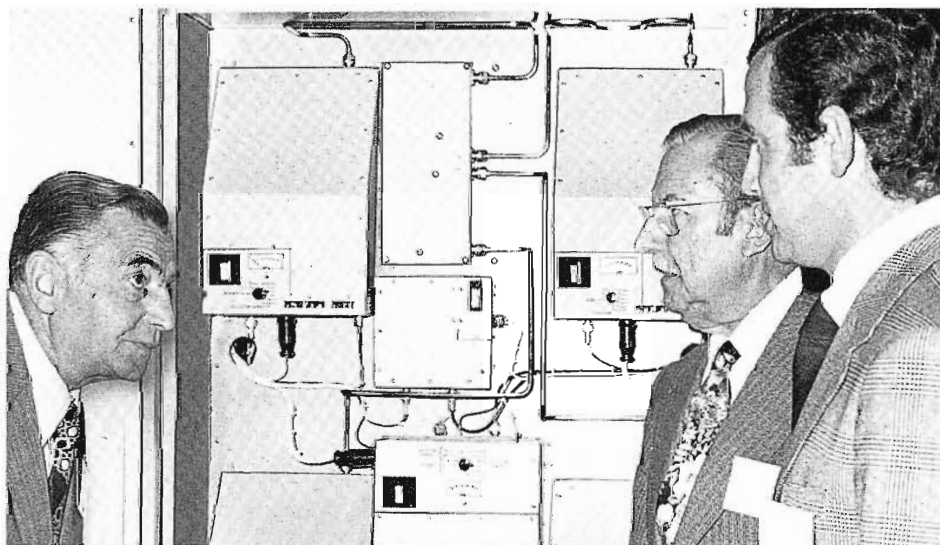

TK-28B telecine islands to enhance TV film handling.

Five TK-76 cameras, also included in the purchase, will be used to expand ENG capabilities.

## WSM-TV Expands Studio Production Facilities

WSM-TV, Nashville, Tenn., has upgraded its studio production facilities with three new RCA TK-47 color television cameras and a TKP-46 studio-quality, hand-held camera.

WSM-TV's TK-47 cameras are equipped with "Autocam", the total automatic capability which permits camera setup at the touch of one pushbutton. Lee Whitehurst, Director of Engineering at WSM Inc., said "The automatic set up system will greatly increase station production time by allowing us to be on 'live' more quickly each day, and, more importantly, with consistent quality."

The TKP-46 portable camera will be used in the studio for creative production spots.

Mr. Whitehurst noted that the addition of the latest-model camera equipment to the Channel 4 studios is another innovative step that has marked television production at the Nashville facility through the years. "As the first television station on the air in Nashville, as well as the first to telecast in color, WSM-TV has been known for its pioneering spirit in using the most advanced equipment available," he said.

## Pakistan Television Corp. Installs RCA Telecine Systems Valued At \$600,000

The Pakistan Television Corp. has expanded the television film handling facilities of its new flagship station with RCA telecine systems valued at approximately \$600,000.

The equipment, installed at the network's headquarters station in Islamabad, the new capital of Pakistan, provides for originating 16mm and 35mm motion picture and slide material, all interlocked with a synchronous sound system.

The two RCA TK-28B telecine systems are equipped with TP-55 multiplexers, TP-66 16mm projectors and TP-7 35mm slide projectors.

Two FR-35 projectors handle 35mm motion picture film originations. The FR-35 features built-in "Servolock" control and drive logic for smooth film handling and accurate interface with other equipment. A PM-86SL magnetic sound recorder/reproducer also will be electronically interlocked with the system to provide synchronous sound.



CAMERAS FOR CABLE NEWS—Jim Kitchell (center), Senior Vice President, Cable News Network, signs an order for twenty-nine RCA studio and field color TV cameras to equip CNN's news centers and bureaus. James A. Gimbel (left), Director, Marketing, and Jerry E. Smith, Manager, Southern Broadcast Sales, accept the order for RCA Broadcast Systems.

## Cable News Network Orders \$1.8 Million In RCA TV Cameras

Cable News Network has purchased RCA studio and field color television cameras valued at approximately \$1.8 million to equip the 24-hour news service's news centers and bureaus.

Six RCA TK-47 automatic studio cameras and twenty-one TK-76C portable electronic newsgathering cameras are included in the order for the Atlanta-based news organization.

The top-of-the-line TK-47 cameras have been installed in Cable News Network's headquarters and production facilities in Atlanta, as well as in CNN's major bureau studio facilities in New York City and Washington, D. C.

The TK-76C portable cameras provide on-the-scene live and recorded news coverage through all seven of CNN's domestic news bureaus scheduled for operation in New York City, Washington, D. C., Chicago, Miami, Houston, San Francisco, and Los Angeles, as well as Atlanta.

Reese Schonfeld, President of Cable News Network, said the 24-hour continuous news programming service, ex-

clusive to the cable industry, begins June 1, 1980, providing coverage of national and international events, financial reports, sports events, weather reports, and news features, highlighted by a two-hour prime-time in-depth world and national newscast, Mr. Schonfeld said.

## Taft Broadcasting Orders For Six Group Stations

Taft Broadcasting Co., Cincinnati, Ohio, has ordered RCA color television broadcast systems valued at approximately \$1 million for its six group TV stations.

The equipment order includes video tape cartridge systems and ENG/EFP color TV cameras.

Three Taft stations each are adding a second TCR-100 video tape cartridge recorder: WDAF-TV, Kansas City; WTAF-TV, Philadelphia; and WTVN-TV, Columbus.

WDAF-TV and WTVN-TV also are expanding electronic newsgathering operations with TK-76 portable cameras. Additional TK-76's have been ordered for WGR-TV, Buffalo; WKRC-TV, Cincinnati, and WBRC-TV, Birmingham, Ala. (which is also adding a TK-760 studio/field camera to increase program production facilities).

## New Commercial UHF For Southern New Jersey

Renaissance Broadcasting Corp. is establishing a commercial television outlet in Southern New Jersey, in Vineland, with RCA broadcast equipment valued at more than \$2.7 million.

The new station, with call letters WRBV-TV, is scheduled to go on the air later this year, broadcasting on Channel 65 at 3.6 megawatts of effective radiated power. It will feature regular commercial programs during the day, and will operate as a subscription TV station in the evening.

RCA equipment to be installed includes a 110-kilowatt UHF transmitter, antenna, and complete studio and field program production and origination equipment.

The studio equipment complement includes color TV cameras, quadruplex video tape recorders and a fully-

equipped TK-28B telecine island. Complete switching and audio systems also are included in the order.

Donald C. McMeans, President and General Manager of Renaissance Broadcasting, said that during the day WRBV-TV will feature commercial programming as well as locally-originated news and public affairs programs of the station's coverage area, from Atlantic City to Camden and south to Cape May.

The station will field four electronic newsgathering units, equipped with RCA TK-76C cameras and videocassette recorders. One of the units will be stationed at the State House in Trenton to cover breaking political news.

From 8 P.M. to 2 A.M. WRBV-TV becomes a subscription TV outlet, with programming provided by Wometco Home Theater, Mr. McMeans said.

## **New TV Station For Reading, Pa.**

Reading Broadcasting, Inc. has established a new independent UHF television station to serve Reading, Pa. and surrounding areas. The new outlet, operating on Channel 51, is scheduled to go on the air with call letters WTVE.

Transmitting and studio equipment valued at more than \$1.5 million is being supplied by RCA. The transmitting plant included a TTU-60 60 kW transmitter, and a pylon antenna.

Studio equipment being installed includes RCA studio video tape recorders, telecine systems, TK-760 studio/field production cameras, and TK-76 ENG cameras.

## **Telemobile, Montreal, Expands Teleproduction Capabilities**

Telemobile, a television program production facility based in Montreal, Quebec, has greatly expanded its teleproduction capabilities with the addition of three RCA TK-46 color TV cameras.

Pierre Gaston, owner of Telemobile, said the cameras will be used for on-location broadcasts of major sports events, and with one-inch video tape recorders for producing high quality TV programs throughout Eastern Canada.

In addition to the TK-46 cameras, Telemobile also fields a mobile TV unit equipped with RCA TK-76 hand-held cameras.

## **Silvio Santos, Brazil, Orders \$700,000 in RCA TV Studio Equipment**

TV Studios Silvio Santos, Ltda., headquartered in Sao Paulo, Brazil, has ordered RCA TV studio equipment, valued at approximately \$700,000, for its program production center.

The equipment order includes four TK-46 color studio cameras and a complete TK-28B TV film origination system.

Silvio Santos, which produces programs for its network stations in Brazil and for other outlets in Latin America, will use the new RCA equipment to expand the production and origination facilities of its Sao Paulo studio complex.

## **Channel 4, Sao Paulo, Brazil, Begins Circularly Polarized Broadcasts**

Channel 4, Sao Paulo, Brazil, will begin broadcasting a circularly-polarized TV signal in 1980, with a new RCA trans-

mitter and antenna system valued at more than \$1 million.

The Sao Paulo outlet of the TV Tupi Network will install a 50-kilowatt RCA transmitter and a VHF Fan-Vee antenna.

The TFV-7A4 antenna, custom-built at RCA's Gibbsboro, N. J. antenna development and manufacturing facility, is a seven-layer system designed for tower top mounting. Each layer is composed of two bays, one for the horizontal component and one for the vertical component of the signal. The bays are properly phased to produce circular polarization.

## **Venezolana de T.V., Caracas, Expands Program Production Capabilities**

Venezolana de T.V., Caracas, which operates two government-sponsored television broadcast networks in Venezuela, is expanding its studio and on-location program production capabilities with RCA television equipment valued at approximately \$1.5 million.

The equipment includes six TK-47 automatic color TV studio cameras and three TK-760 studio/field production cameras.

In addition, the order for Venezolana de T.V. includes a "mini" outside broadcast vehicle equipped with three TK-760 cameras and a TH-200 one-inch VTR.

## **New Video Tape Facilities For XEFB-TV, Monterrey, Mexico**

Cadena Televisora del Norte, S.A., has upgraded the technical facilities of XEFB-TV, Channel 3, Monterrey, Mexico, with RCA TV tape equipment valued at more than \$600,000.

Included in the order are two TCR-100 video tape cartridge recorders which are equipped with a built-in automation accessory that provides for electronic cartridge identification, automation system interface and programmable random play of cartridges.

A TH-50 portable one-inch VTR also is included in the equipment order and will be teamed with RCA studio and hand-held cameras already in operation for local commercial and program production assignments.

## **UA-Columbia Cablevision Inc. Equips San Antonio Teleproduction Studios**

UA-Columbia Cablevision Inc. has ordered RCA television studio systems valued at more than \$1 million to produce community programs for its cable system serving San Antonio, Tex. and environs.

The San Antonio-Bexar County cable

facility, covers approximately 2,500 miles, according to Kenneth Gunter, Executive Vice President, UA-Columbia.

The television systems on order from RCA Broadcast Systems will equip three TV studios and a mobile TV van. The studios and mobile unit will give community groups easier access to their cable system, Mr. Gunter said. Two-way microwave systems will link the two satellite studios to the main studio where programs will be fed to the cable system, he added.

The TV studio equipment installed by RCA includes TK-760 color cameras, TH-200 one-inch video tape recorders and a TK-28 film origination system. A TK-76 hand-held camera and a TH-50 portable recorder handle on-location production capabilities.

The compact mobile TV van, to be used for field recording of local news, sports documentaries and other programs, is equipped with TK-760 cameras and a TH-50 portable recorder.

## **WNGE-TV Upgrades With RCA Cameras And Telecine Systems**

WNGE, Nashville, Tenn., a General Electric Broadcasting Co., Inc. station, has modernized its television studio technical facilities with RCA broadcast equipment valued at approximately \$650,000.

The equipment order includes three TK-47 automatic color television cameras, and two complete TK-28B telecine islands.

The TK-47 cameras for the Channel 2 station include the total automatics accessory which sets up the camera for optimum performance at the touch of one pushbutton.

## **WBAL-TV, Baltimore, Adds TK-47 Cameras**

WBAL-TV, Baltimore, a Hearst Corporation station, is upgrading its studio and field production capabilities with RCA color television cameras and tape recording equipment.

The equipment, valued at more than \$500,000, includes three RCA TK-47 studio/field cameras. The TK-47 features automatic functions for simplicity of operation, and microprocessor-controlled automatic camera set-up.

The station also has enhanced its electronic newsgathering and on-site production facilities with two additional TK-76B portable color cameras, a TH-50 portable one-inch helical scan video tape recorder, and a TH-100 one-inch studio model VTR.

## Broadcast Television Vehicles For Algeria

Radio Television Algeria is advancing its move to its full-color operations and expanding its in-the-field television program production capabilities with four RCA outside broadcast vehicles, valued at approximately \$3.5 million.

The mobile TV vehicles are custom-built at RCA Broadcast Systems' manufacturing facility in Jersey Channel Island, England.

Two of the vans, equipped for video tape operations, have been placed in service for the colorization of existing TV channels in Algiers, and in the surrounding provinces. Each van is equipped with two RCA TR-600 quadruplex video tape recorders with built-in AE-600 time code editing systems, as well as complete monitoring and control

equipment.

Two additional vans, scheduled for delivery later this year, will be employed for on-location production assignments throughout the country. Each will have three TK-46 cameras and one TKP-46 portable production camera installed. The completely-equipped vans also will include associated audio, monitoring and control facilities and a production switcher. Microwave relay capabilities also will be included in each van.

Programs covered by the new outside broadcast vehicles will be fed via microwave to the RTA stations for direct on-air use, or for video taping in the studio. In addition, the video tape recorder vehicles will be available for on-site taping of programs for later broadcast.



### Banister Named Vice President, Broadcast Systems, Europe, Africa & Middle East

Jack E. Banister has been promoted to Vice President, Broadcast Systems, Europe, Africa and the Middle East.

In his new assignment Mr. Banister heads an organization that manufactures and markets RCA studio and transmitting systems for radio and television broadcasting. He is based at RCA's Sunbury-on-Thames offices, near London, where he previously served as Directional Director, Marketing, for Europe, Africa and the Middle East.

Mr. Banister has been with RCA since 1973 when he became Manager, Telecommunications Marketing, for the company's Government Communications Systems organization in Camden, N. J. He joined Broadcast Systems in Camden as Manager, Sales Development and Proposals, and later served as Manager, Midwestern Broadcast Sales, and as Manager, Domestic Broadcast Sales.

### RCA Cablevision To Provide 90-Mile System In Los Angeles Area

A contract to supply and install a 90-mile cable TV system in two Los Angeles area communities for Jack Barry Cable Television was awarded to RCA Cablevision Systems.

The 35-channel system, the first venture for the television star's new cable company, will cover a potential 20,000 to 25,000 subscribers in Westchester and Playa del Rey.

Bernie Czarnecki, the cable company's General Manager, said that programming is being planned for 29 of the system's 35 channels, including two pay TV offerings—Home Box Office and Warner's movie channel—as well as 16 off-air TV station pickups and a variety of other cable TV programs and services.

### Klerx Named Managing Director, RCA Jersey Ltd.

Henry H. Klerx has been appointed Managing Director, RCA Jersey Ltd., with executive responsibility for the company's facilities on Jersey, Channel Islands.

The Jersey plant produces TV cameras, video tape recorders and other broadcast equipment for RCA customers in Europe and in the African and Middle East markets.

Before his promotion, Mr. Klerx was Manager, Planning and Marketing Services, for the RCA Commercial Communications Systems Division, in Camden, N. J.

Mr. Klerx has more than 26 years of managerial and technical experience in RCA's broadcast equipment business.

For the 1959-71 period Mr. Klerx headed merchandising and product planning activities for the RCA electronic recording product line and was identified with many advances in that area.

After serving as Manager, Broadcast Equipment Planning, he was named Manager, Studio and Control Equipment Engineering and Product Management, Broadcast Systems, in 1974. He

was promoted to the Division planning/marketing services position in 1977.

### Francis X. Carroll Promoted To Division Vice President, Finance

Francis X. Carroll has been promoted to Division Vice President, Finance, for the RCA Commercial Communications Systems Division, Camden, N. J., with responsibility for the administration and control of all Division financial matters worldwide.

Carroll, who joined RCA in 1951 as a management trainee in Camden, most recently was Director, Finance, for the Broadcast Systems business unit. He had been its chief financial officer since 1972.

He is a member, Board of Directors, of RCA Jersey Ltd., and of the RCA Broadcast Systems International Corporation.

A native of Philadelphia, Mr. Carroll was graduated from St. Joseph's Preparatory School and St. Joseph's College, the latter with a bachelor of science degree in accounting. He also studied engineering at the Virginia Military Institute and attended the Amos Tuck School of Business Administration at Dartmouth College.



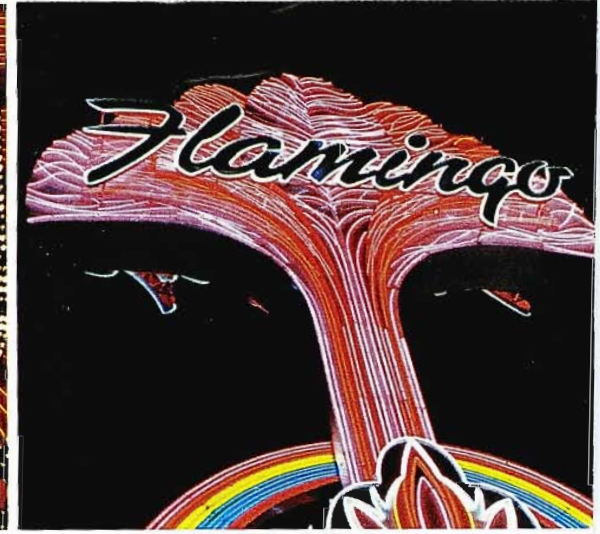
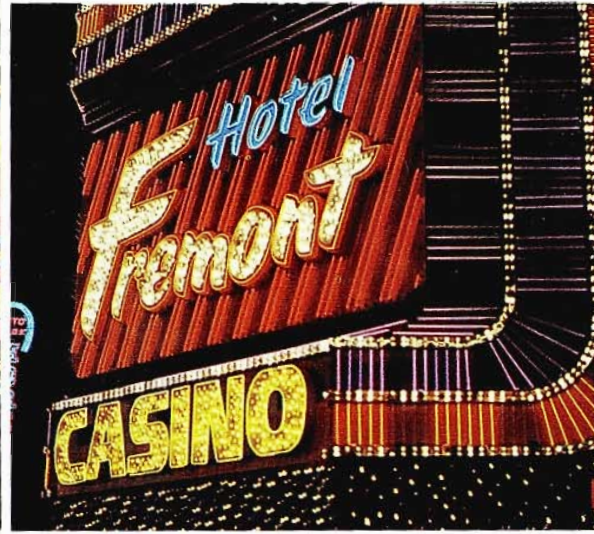
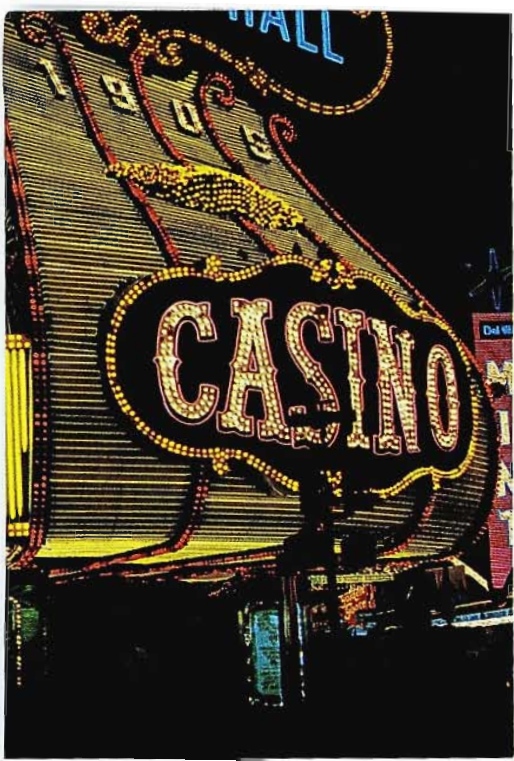

# NAB 1980

## An Auspicious Inaugural for the New Decade

The "Sights and Sounds of the 80's" provided an umbrella theme for the 1980 NAB Engineering Conference. Predictably, "decade" was by far the most popular word at the Convention—seen and heard everywhere throughout the 185,000 sq. ft. exhibit area.

Broadcasters and teleproducers alike anticipated major new developments in technology, in products and in services. And nowhere was the impact of technology more evident than in the large RCA exhibit, which was literally crammed with new product offerings. Among the new product introductions by RCA were:

- TR-800, 1-inch Type "C" VTR, designed and manufactured by RCA, incorporating many welcome new features.
- Complete accessory complement for the TR-800, making it a total video tape system for full versatility.





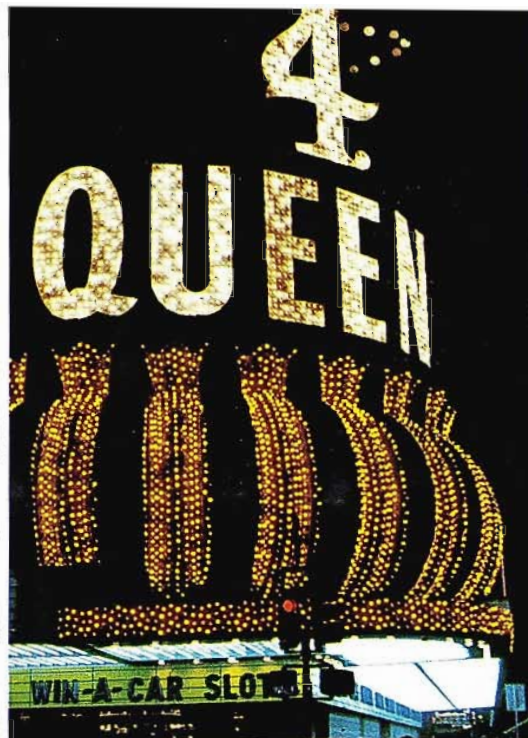
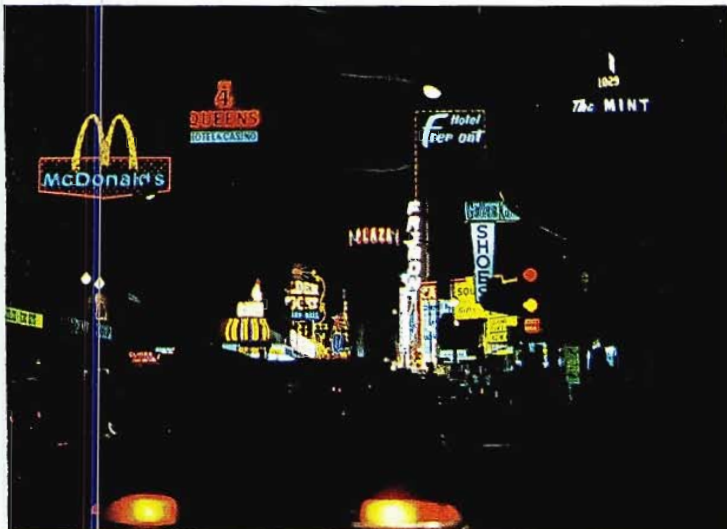

Focus on the sights and sounds of Las Vegas. By night . . . the bright lights. By day . . . action indoors and outdoors at the NAB Convention.

- AE-800 Time Code Editing System for TR-800, a sophisticated system that addresses a wide range of editing needs and which can be integrated into intermixed quad and 1-inch VTR's equipped with AE-600 editing systems.
- AE-600TH Time Code Editing System for TH-200, 1-inch VTR.
- TK-29 Series Telecine Camera, three new models, all featuring the latest in design technology to achieve superior performance and reliability of operation. A worthy successor to the renowned TK-28.
- TK-47EP, the Extended Performance model of the high performance TK-47 automatic camera, using 30mm diode gun lead oxide tubes with narrow angle scan.
- TK-780 Triax Studio/Field camera, providing the advantage of triax op-

eration plus the flexibility and performance of the TK-760.

- TTG-50H and TTG-50/50H, 50 kW and 100 kW highband additions to the TTG Series VHF transmitter family which now offers worldwide users a choice of 22 models.
- TCL-12A Tetra Coil CP antenna for VHF channels 7-13, can be top-mounted on the tower as a direct replacement for a 12-bay Superturndstile.
- BTA-5SS, an all-solid state 5 kW AM transmitter featuring improved efficiency, quieter operation and greatly reduced floor space requirements.

The excitement of the new products carried over to the RCA camera show, an innovative, colorful outdoor production, complete with Indians, tepees and authentic props. Outdoor watchers enjoyed the realism of the production,

while indoor monitor viewers were treated to spectacular performances by a quartet of scene-stealing RCA cameras.

Yes, the 1980 NAB Convention marked an impressive debut for the new decade. And it promises to be a challenging and exciting era for the broadcast industry and for its suppliers.

The array of new products announced by RCA represents a response to the challenges of advancing technology as well as a responsiveness to the changing needs of the industry.

Throughout the RCA exhibition area, the unifying graphic theme was "RCA Does It Again"—a ready reference to the new product developments in tape, cameras, transmitters and antennas.

*Some of the action in various areas of RCA's 1980 NAB exhibit are highlighted on the following pages.*





New AE-800 Editing System for TR-800 is compatible with AE-600 Editing Systems.



The main tape attraction . . . Introducing the all-new TR-800 VTR.

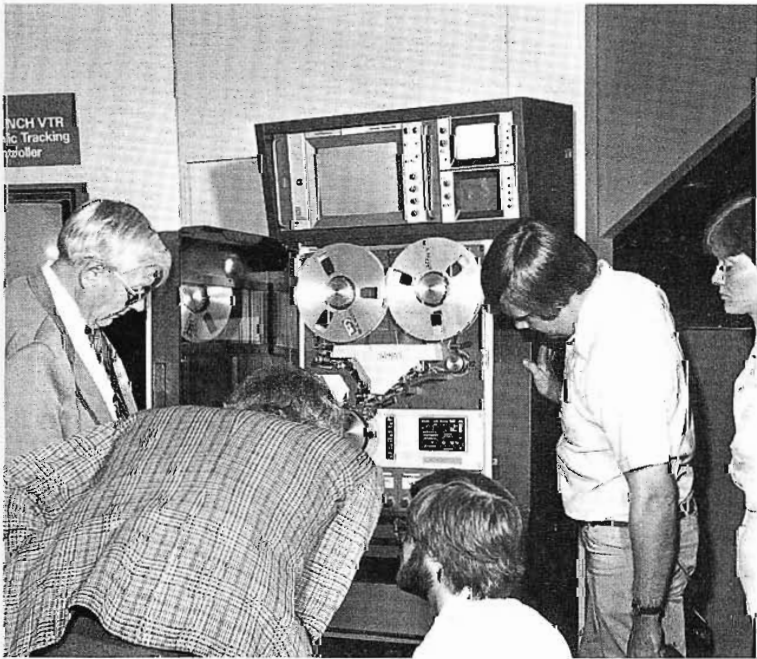

Sustained interest in the TH-200 VTR was evident.



New Dynamic Tracking Remote Controller for the TH-200.



# New RCA 1-Inch Video Tape Line Announced

The new TR-800 Type C VTR introduced at the 1980 NAB was subjected to careful scrutiny by two critical audiences: competitors and customers.

In all aspects—features, performance, versatility, styling and system capability—the TR-800 performed magnificently. All day long during the convention, the TR-800 played to attentive, appreciative crowds. Features of the new tape system were highlighted in a multimedia presentation. But the real show stopper and main attraction was the TR-800 itself. Four operating machines in different system configurations rolled tape continuously.

A microprocessor-based system, the TR-800 offers a full range of features. Record, playback, simul-playback and monitoring are standard, as is a built-in preview editing capability for simple insert edits and automatic or manual additions. A unique tape handling system provides for easy threading and the ability to accommodate two-hour tape reels. Servo motors provide fast acceleration and winding speeds, with full control and gentle tape handling.

Along with the TR-800, a complete complement of system support acces-

sories was demonstrated, including:

“Supertrack”, an advanced tracking system

Multi-Rate Video Controller for “instant replay” and other production uses

“Super Search Editor”, a programmable system with keyboard for expanded editing capability

Time Code Modules—TC Generator, TC Reader and Video TC Processor—prepare the TR-800 for time code editing

TBC-8000 Time Base Corrector uses 4X subcarrier sampling and a 10-line correction window for superior broadcast picture quality.

Also demonstrated was the AE-800 Time Code Editing system designed to match the TR-800’s unique capabilities, including synchronization of playback machines at variable speeds, in forward or reverse.

Other features of the versatile AE-800 system: six preview modes; split audio and video edits; auto and manual update modes; master recall mode; programmable relay closures.

While the introduction of the TR-800 and its system accessory complement rated top billing, other significant additions to the RCA tape line were also demonstrated. Among these:

Dynamic Tracking Remote Controller to add “instant replay” capabilities to the TH-200 one-inch VTR’s.

AE-600 Time Code Editing System adapted to the TH-200. This complete editing facility for the TH-200 also accommodates a variety of system arrangements, including intermixed operation with TR-600A quad machines, and is compatible with the new TR-800/AE-800 system. (This mixed system capability was demonstrated in the exhibit.)

TH-50 Portable 1-inch VTR’s were operated in two modes: as a studio playback machine and as a remote unit, with a full complement of accessories to enhance field operation.

Video tape equipment occupied substantial space in the RCA exhibit—and also contributed more than its share of action and interest.

The TR-800 presentation was informative, entertaining and popular with NAB visitors.

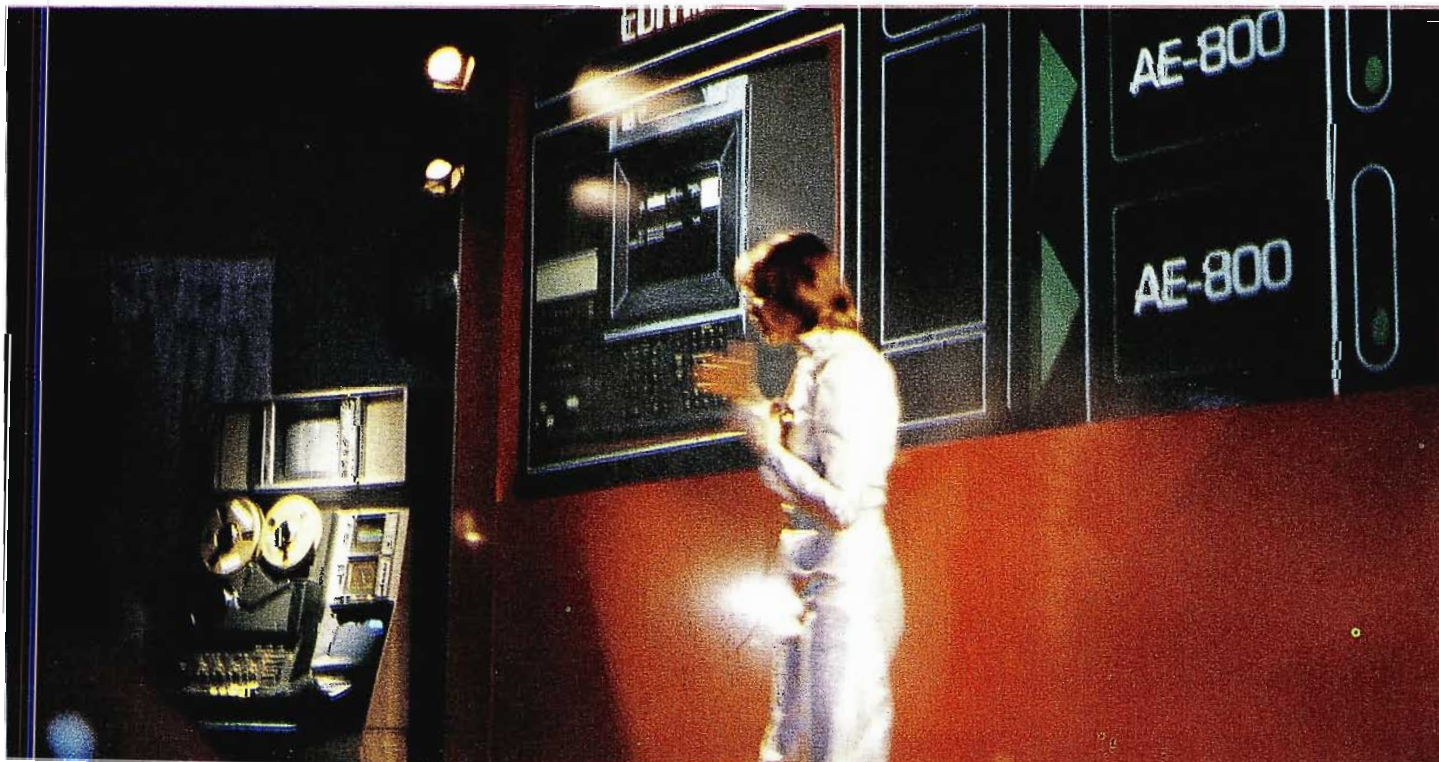



Talented TK-47 Camera demonstrates its picture-perfect capabilities on the outdoor set.

## CAMERA SHOW An "On-Location" Production



Innovative outdoor production featured teepees, Indians, rain dances and four RCA cameras, including a TK-76C portable riding a cherry picker high above the set.

Many NAB attendees got their first look at the RCA camera show before they entered the exhibit area. The studio was on the lawn outside the convention center—an authentic Indian “village”, complete with teepees and colorful artifacts, and featuring performances by Chief Red Hawk and White Feather.

Operating on set were a quartet of high performance RCA cameras—the TK-47; TK-760; TKP-46 and TK-76C.

The cameras demonstrated their ability to operate under uncontrolled lighting and other ambient conditions faced in field production. Monitors inside the RCA exhibit displayed crisp, brilliant color pictures from the location set to large groups of attentive viewers.

The TK-47 reproduced every scene to perfection, showing again that it is today’s premier top-of-the-line camera—simply the most technologically advanced camera system available.

The TK-760 with its 30:1 zoom lens moved from long shots to the tight, detailed close-ups that delight sports directors and fans alike, producing superb color pictures through the entire range.

The TK-76C, ENG/EFP portable camera roved about the outdoor set, then rode a “cherry picker” platform above the set, demonstrating a wireless application of the camera, with a portable microwave system transmitting pictures to the inside monitors. Enhancements to the TK-760 and the TK-76C include a

new system for contrast compression, and an increased gain mode for operation in low light levels.

Rounding out the outdoor set camera coverage was the TKP-46 Production Portable displaying its talent for delivering studio quality pictures anywhere—in the field, or in the studio.

Day after day Red Hawk and White Feather performed a typical Indian rain dance on the set, challenging the elements to rain on RCA’s camera parade. Although the rain never came, the outdoor production was scheduled to continue without interruption. In fact, it was a small disappointment that the cameras were denied the opportunity to perform under wet skies.



Camera "show" inside the RCA exhibit featured a full set with an Indian motif, but the main attraction was "hands-on" operation of the cameras.

## INSIDE CAMERA SHOW "Hands-On" Production



Outside-in. Audiences eye monitors to check performances of RCA cameras operating on the outdoor set.

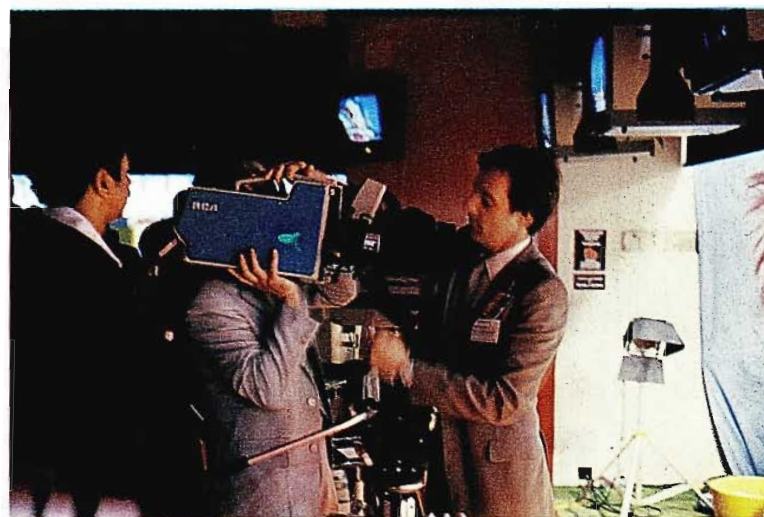

TK-76C gets "hands-on" check.

The inside studio was set up for "hands-on" operation of the cameras. Two new models of broadcast cameras were demonstrated, along with an advanced development model of a CCD camera.

One of the new cameras is the TK-47EP, an extended performance version of the TK-47. The new camera model achieves improvement in several performance parameters, including higher signal-to-noise, reduced geometric distortion, improved registration accuracy, excellent resolution on axis and in corners, lower lag and higher beam reserve. The TK-47EP employs 30mm diode gun lead oxide tubes which feature narrow angle scan and low-capacity signal electrode for improved resolution, particularly in picture corners.

Also shown for the first time was the TK-780, a triax version of the TK-760. The new camera retains the flexibility and the operational and control features of the TK-760, and in addition, can be operated with up to 5,000' of triaxial cable. The TK-780 also is easily con-

verted into the hand-held TK-76C portable for ENG/EFP operations, as is the TK-760.

The CCD (Charge Coupled Device) camera demonstrated attracted considerable attention. It was a development model similar to one supplied by RCA Electro Optics and Devices to the National Geographic Society for use in a special marine biology research expedition in the Pacific Ocean. At depths approaching 9,000', the camera produced pictures of marine life forms never before known to exist. The demonstration served as a progress report on CCD camera technology. Cameras using CCD image sensors instead of pickup tubes are coming, but broadcast quality units are still a few years in the future.

In an environment where change is constant, RCA camera products continue to evolve to meet present and future needs. This NAB confirmed the wisdom and necessity for doing so.



New CCD camera model.



The TTG Series VHF TV Transmitter line was expanded with the addition of 50 and 100 kW highband models.

Transmitter Engineering Manager Robert Unetich discusses the solid state driver design of the TTG Transmitter.

The new bright sound in radio was demonstrated by the all-solid state BTA-5SS AM Transmitter.

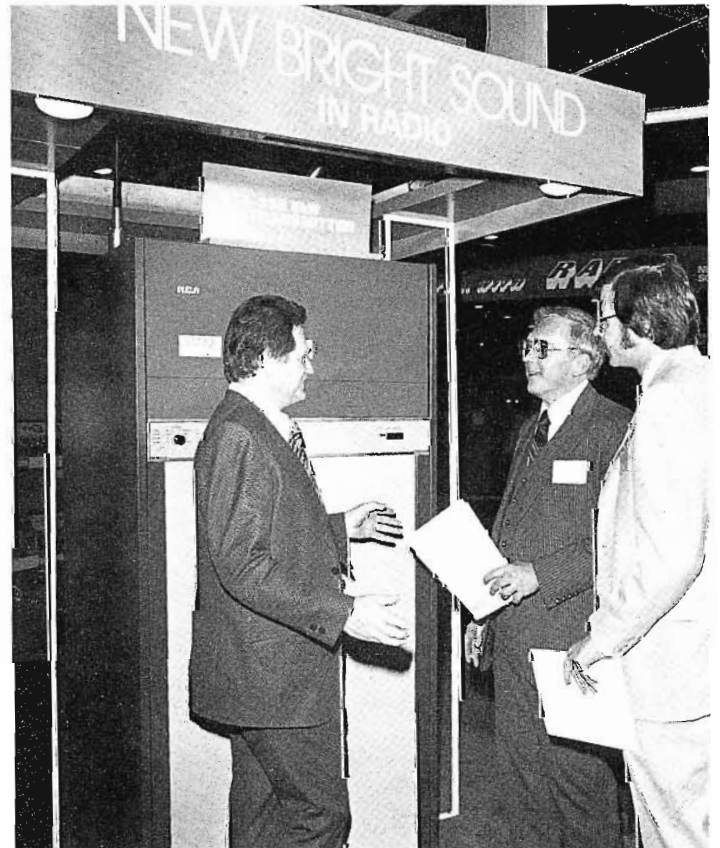
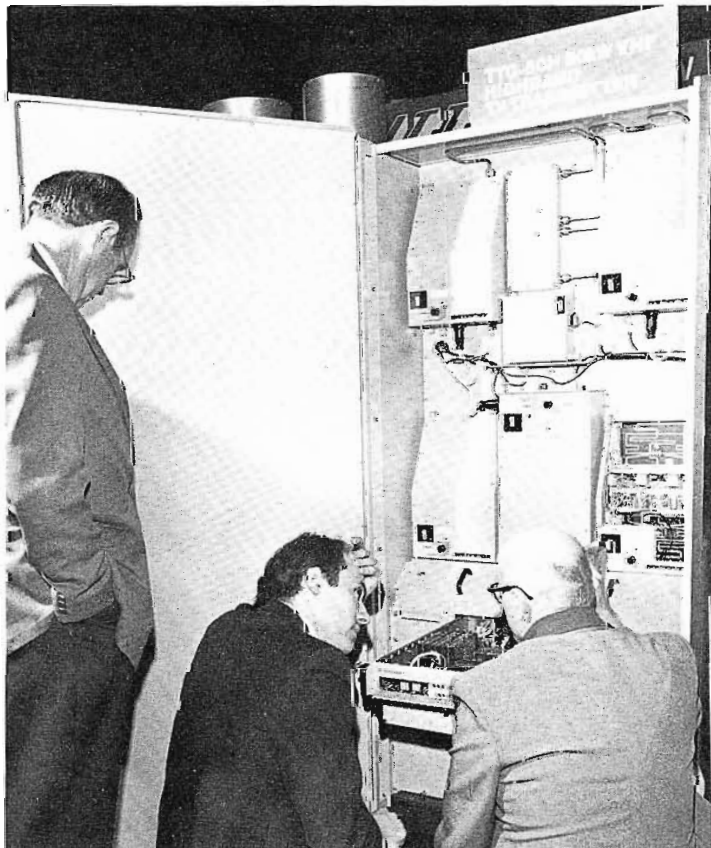



# New Transmitters for TV and Radio

RCA television transmitters made major news at the 1979 NAB, with the introduction of the totally new solid state TTG Series of VHF transmitters. For 1980, the line has been expanded with the addition of two new high power highband systems—the TTG-50H, a 50 kW single ended system, and the TTG-50/50H, a 100 kW parallel system.

For radio, a new 5 kW solid state AM transmitter, the BTA-5SS, was operated at full power into a dummy load, with typical program material from records and tape available for listening.

## 50 kW Output With Only Two Tubes

The TTG-50H uses only two tubes—one visual and one aural. All of the advanced design features of the TTG series are in-

cluded: solid state to 1600 watts visual and 100 watts aural, with only one tuned linear amplifier stage; automatic power level control; heat pipe cooling of IPA transistors; universal crystal oscillator and frequency synthesizer.

The TTG-50/50H is especially suited for broadcasters operating from tall towers, 1500' or more, where extra transmitter power is needed to compensate for transmission line loss. Both the 50 and 100 kW systems are designed for operation with circularly polarized antennas where higher power levels are required for signal radiation.

With the two new highband systems, the TTG Series offers worldwide users a choice of 22 VHF transmitter models,

with a broad range of power levels and system configurations.

## New Modulation Technique for AM Transmitter

In the all solid-state BTA-5SS transmitter, a new modulation technique—Pulse Linear Modulation—is used for extended audio performance. The PLM system provides low distortion, wide audio frequency response, fast transient response, high modulation levels and high efficiency.

The new transmitter is capable of 125% asymmetrical modulation at full rated power, and was designed with stereo operation in mind.

## Circularly Polarized Antenna Line Expands

### New TCL-12A Tetra Coil

Introduced at NAB was the TCL-12A Tetra Coil Antenna for VHF Ch. 7-13.

Designed for top mounting on the tower, the TCL-12A is made up of two layers of radiating elements, each consisting of four conductors. The antenna produces a power gain of approximately five in each polarization.

The design of the TCL-12A results in windload characteristics which permit it to be installed on the tower as a direct replacement for a 12-bay Superturnstile Antenna.

### Five Other CP Antennas Displayed

In addition to the TCL-12A, five more circularly-polarized TV broadcast an-



tennas were also displayed. These included:

TCL-16, a three-layer Tetra Coil for highband VHF, with a power gain of eight in each polarization.

TBJ, for VHF Ch. 7-13, a side mounting panel antenna with three panels per layer for mounting on a triangular tower.

TDM, top mount dual-mode antenna

for Ch. 2-6, a direct replacement for existing 6-bay Superturnstile antennas.

TBK, Quatre Foil, for Ch. 2-6, a side mounting panel antenna with a power gain of one-half per layer in each polarization.

TFU-CP, a UHF circularly polarized antenna designed for direct mechanical replacement of horizontally polarized UHF pylon antennas.

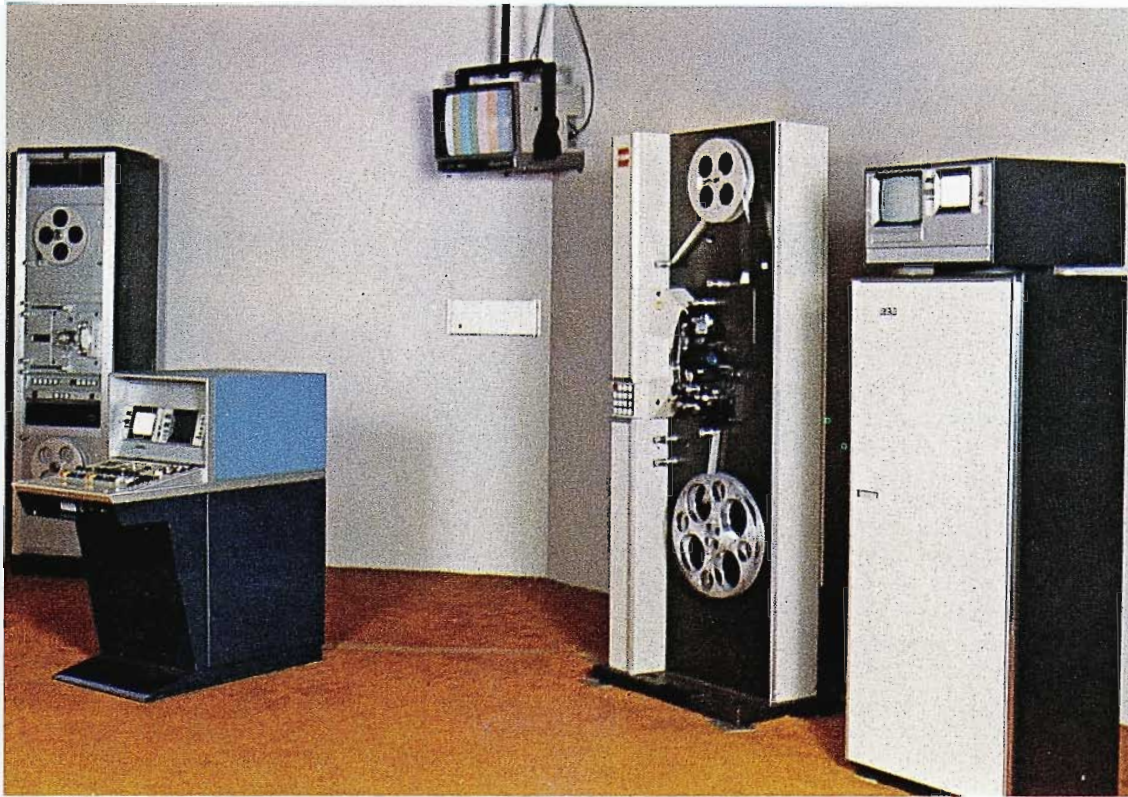

The new TK-29C Teleproduction Telecine Camera with FR-35 35mm Projector and programmed color correction system was a center of attraction.

## TELECINE: The Excitement Transfers To Film

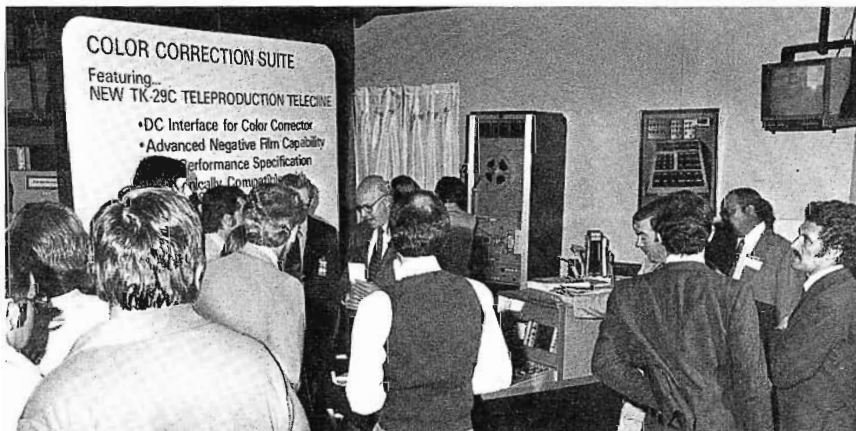

**T**elecine made exciting news at NAB, highlighted by the introduction of a major new product—the TK-29 Series Telecine Cameras. In replacing the long-running industry favorite TK-28, the new TK-29 becomes the RCA standard bearer.

Three TK-29 models are available, all featuring the latest in design technology to achieve superior performance and reliability of operation. The three models are designated as: Standard Broadcast Telecine; High Performance Telecine, and Teleproduction Telecine. Noteworthy features include a new preamplifier design; computer-matched deflection yokes; video processing circuitry; automatic color correction; advanced negative film processing electronics.

### Color Correction Suite

A color correction suite in the telecine area had the TK-29C Teleproduction Telecine teamed with an FR-35B 35mm Projector, a PM-86SL SepSound System and a multiple event programmer to demonstrate the programmable color correction capabilities of the new camera. The TK-29C includes a built-in D. C. interface for controlling 29 variable functions to correct colorimetry, contrast and exposure of film and slides.

A second telecine island included a TP-55 Multiplexer with TP-7, TP-66 and FR-16 Projectors, all wearing the new colors of beige and gray, a pleasing combination.

## A Full RCA House

Sharing NAB exhibit space with Broadcast Systems were several other RCA operations which also supply products and services for broadcasters.

### Technical Services, Camden, NJ

The Broadcast Systems customer service operation, includes Tech Alert, Project Management; Systems Engineering; Custom Repair; Assembly and Engineering facilities.

### Service Company, Cherry Hill, NJ

A range of services available, among them: a new TCR-100 field overhaul program; TK-76 camera rentals, and

satellite communications services.

### Mobile Communications Systems, Meadow Lands, PA

“TAC” line of professional radios for all frequencies and power requirements to serve any 2-way communication need.

### Cablevision Systems, Hollywood, CA

Demonstrated an RF Signal Distribution System for economical in-house monitoring.

### Electro Optics and Devices, Lancaster, PA

A full line of “Camera Ready” pickup

tubes, including new design Saticons.

### Americom, Princeton, NJ

Satellite communications facilities. Introduced a new service, “ADDS” (Audio Digital Distribution Service) which permits use of satellites for distribution of radio programming, wire services or specialty programming to a large number of affiliates.

Also demonstrated the highly successful SMARTS system, a secure, economical method of video program distribution via satellites.

# New TK-29 Series Telecine Cameras

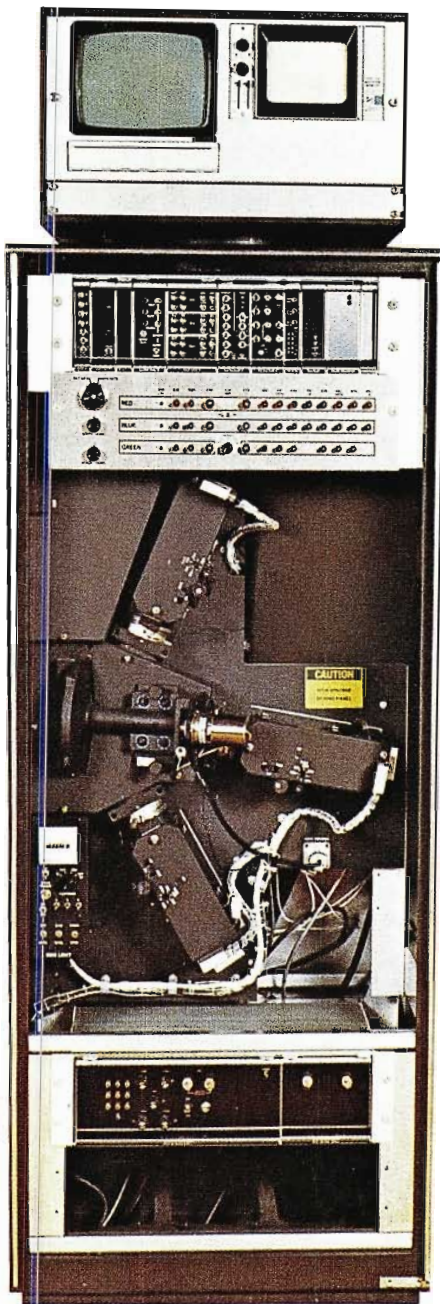

Inside the TK-29C, with the door removed.

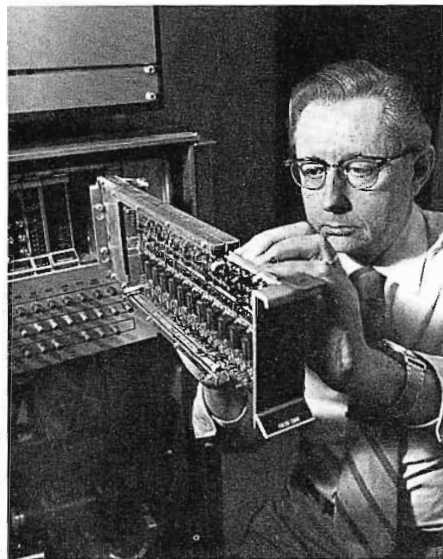

Color Correction module for the TK-29C.

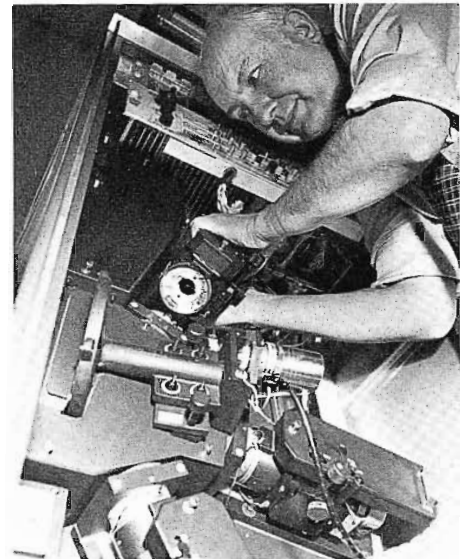

New precision yoke assembly for TK-29 Cameras.

**TK-29B High Performance Broadcast.** Designed for broadcast and teleproduction systems where superb picture quality and unattended operation are important.

**TK-29C Teleproduction Telecine.** Special features and built-in D. C. interface make this model the ideal choice for a correction suite and for film-to-tape transfer work where programmable color correction is required.

All TK-29 Series cameras feature a new preamplifier design with excellent signal-to-noise performance, achieved by coupling the input semi-conductor device directly to the pickup tube target.

New design computer-matched deflection yokes provide for excellent and repeatable registration and for improved focus. Pickup tube options include: 25mm vidicon or Saticon tubes, or 30mm lead-oxide tubes with integral bias light (TK-29B and C).

Operation with narrow horizontal blanking also is included to accommodate teleproduction requirements.

#### Aperture Correction and Contour Enhancement

The TK-29 Series cameras also feature high performance aperture correction and contour enhancement circuitry to bring fine details in the picture, and fully automatic color correction to handle film color balance and exposure problems. Aperture correction is separately adjustable for H and V. Contour correction is applied by linear addition to the luminance signal which maintains picture

sharpness over the full film gradation range, including the darker picture areas.

#### Negative Film Processing

Advanced negative film processing electronics enable the camera to handle many types of negative film stock. The TK-29 reproduces negative film images of wide density range without sacrificing picture quality.

#### Teleproduction Model, TK-29C

The top-of-the-line TK-29C Teleproduction Telecine includes a built-in D. C. interface which allows control of 29 variable parameters that affect and correct film exposure, density, contrast, colorimetry and color saturation. The full operational range of any control can be accommodated by a D. C. voltage swing of +10 volts. In addition, operational switched controls that are normally preset can be removed. The switch controls are also D. C. voltage operated and control is available at a connector on the TK-29C. The D. C. interface is designed to work with commercially available or custom-designed computer-controlled programmable color correction systems.

The TK-29C is a perfect match to RCA FR-16 and FR-35B teleproduction variable speed projectors, and separate magnetic sound equipment.

#### Multiplex Compatibility

All TK-29 Series Telecine Cameras are available in NTSC, PAL-M and PAL-B standards. The new cameras are mechanically interchangeable with TK-27 and TK-28 cameras and can directly replace these in existing telecine systems.

A major new product introduction for RCA was the TK-29 Series Telecine Cameras, a new generation successor to the TK-28.

Three different models are offered in the TK-29 Series of photo-conductive telecine cameras:

**TK-29 Standard Broadcast.** Intended to upgrade the performance of any multiplex telecine chain, this model is an excellent replacement for TK-27 and TK-28 telecine cameras.

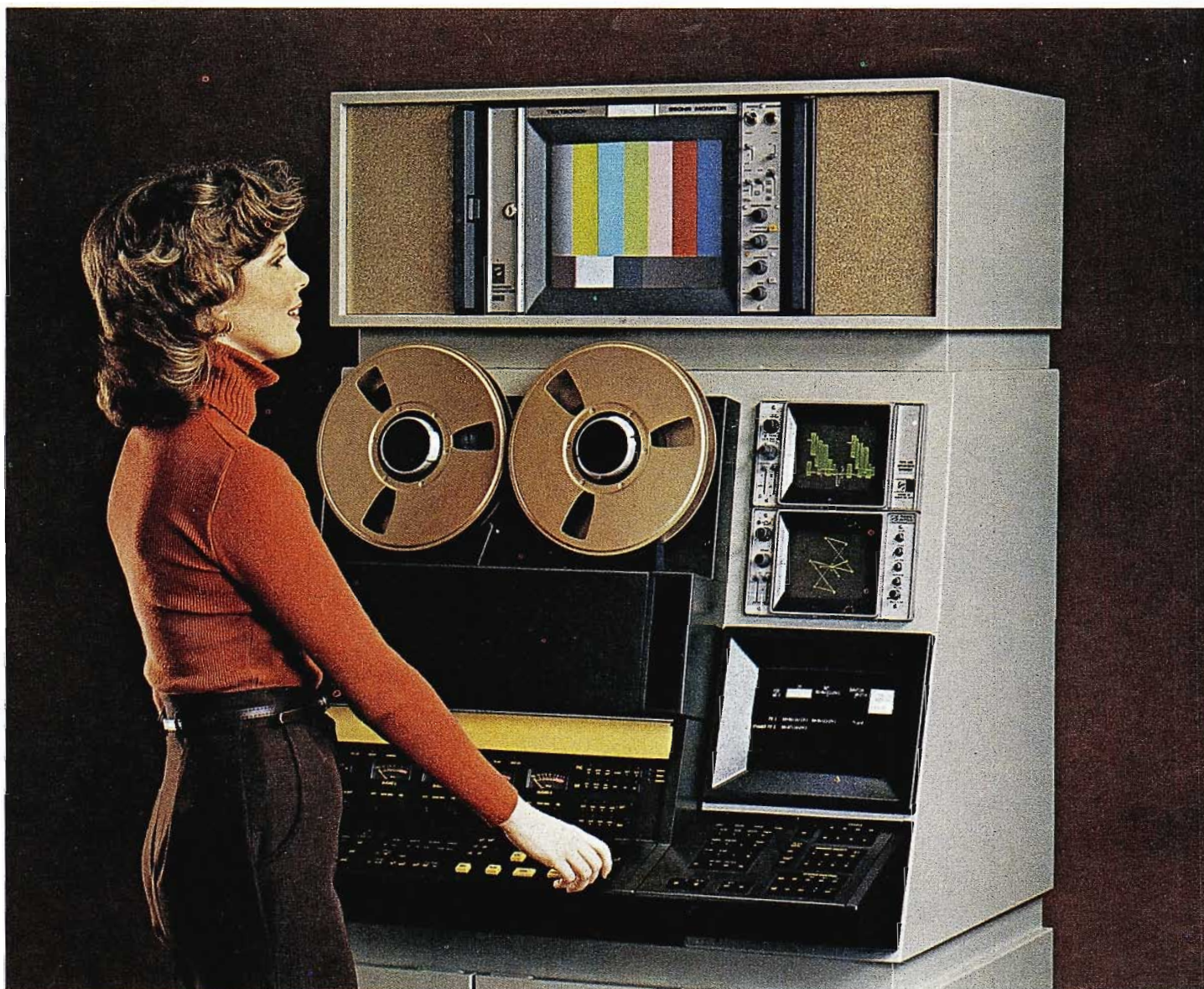

TR-800 VTR with AE-800 Editing System mounted in a studio console with overhead monitor bridge.

## TR-800: A Totally New 1-Inch VTR With System-Compatible Components For Complete Versatility

The TR-800 one-inch Type C VTR is more than a new video tape recorder—it is the centerpiece of a complete new VTR product line, designed and manufactured by RCA which offers users a full range of total system options and capabilities.

The basic Transportable TR-800 is compact, attractively styled, easy to operate, and incorporates a whole complement of standard features to take advantage of the "C" format. Record, playback, simul-playback and monitoring capabilities are standard, as is a built-in previewable editor which provides insert edits and automatic or manual add-ons. Audio and video performance specifications are superior.

### Microprocessor-Controlled System

An advanced, microprocessor-controlled system, the TR-800 offers unprecedented-



Machine controls for TR-800 are centrally grouped for operator convenience.

ed control and operational facilities. The recorder's operational capabilities, including video, sync and multiple audio channels, can be addressed from one control center, with indicators providing visual confirmation. In addition, full remote control capabilities are built into the TR-800 to meet operational needs, from a simple side-by-side slave configuration to the most sophisticated computer-addressable multi-machine complex.

#### Unique Tape Handling Facilities

The TR-800 features a unique tape handling system that provides ease of threading, gentle tape handling, and the ability to accommodate two-hour reels without component changes.

Servo motors permit attaining unexcelled acceleration and winding speeds while eliminating tape stress. At an acceleration of 125 inches/second/second, a 90-minute reel of tape can be totally rewound in less than 120 seconds. Dynamic braking and bi-directional end-of-tape sensing provide tape protection with full control.

Simple threading is achieved with the "Guidetrack" tape path. Transport tension elements, pinch roller and audio shields are completely retracted to provide an unrestricted threading path, with a natural flow from supply to take-up. Fast action hub locks allow any size reel to be popped on and off, with fingertip control.

#### Serviceability Features

Also unique to the TR-800 is a new tape scanner assembly that is screwdriver-adjustable and is quickly and easily replaced in the field without special tools.

Innovative packaging of the TR-800 electronics provides full accessibility from the front for service, while the system remains operational. The control panel drops down to expose the main module nest.

The basic TR-800 system is the transportable unit, a compact 175 pound package completely self-contained. Other available configurations include the T-Card; the Compact Studio Console, and the Full Studio Console with monitor bridge.

Simple threading is achieved with the "Guidetrack" tape path.

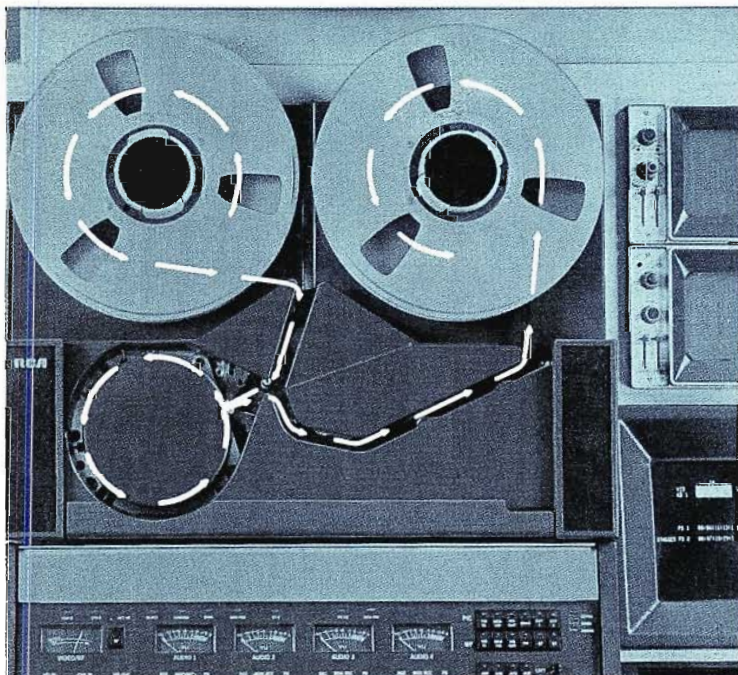

The entire front control panel drops down, exposing system electronics for service.

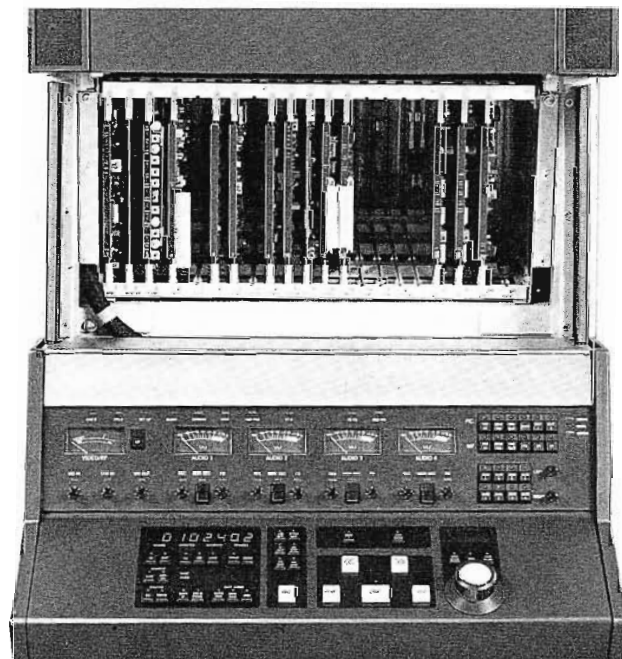

#### System-Compatible Accessories

Alone, the TR-800 is a versatile, full function VTR which delivers outstanding performance—in the studio or in the field; as a record or as a playback machine. However, its utilization is enhanced by a complete line of system-compatible accessory equipment developed to handle total tape system requirements, giving the user a choice of system capability. Among the optional accessories available for handling total system needs are:

#### TBC-8000 Time Base Corrector.

Uses 8-bit quantization, 4 X color sub-carrier sampling and a 10-line window for superior picture quality. The unique RCA "surround" digital dropout compensator, velocity error corrector and digital chroma inverter combine to attain exceptional video performance.

**Supertrack.** This is an advanced tracking system for broadcastable color playback from reverse through

still frame to fast forward. Precise tape control is provided with a single knob, in variable wind, jog and variable play modes. An LED readout confirms the exact tape playback speed with single frame accuracy throughout variable play.

#### Multi-Rate Video Controller (MRVC).

This versatile, desk-mount unit permits variable speed replays in forward or reverse, an excellent production aid. Features include: 9-point permanent memory, "scratch-pad" memory, automatic search-to-cue.

#### Super Search Editor (SSE).

A programmable, microprocessor-controlled accessory which expands the capability of the built-in editor. It includes nine independent search-to-cue points; keyboard entry; playback VTR control; modifiable edit point through the keyboard; a store direct mode to capture edit points "on the fly", and an out transfer mode.

**Time Code Modules.** Three plug-in modules—Time Code Generator, Time Code Reader and Video Time Code Processor—are integral to the TR-800 and prepare the machine for time code editing use. All operate with SMPTE longitudinal or vertical interval time codes.



"T" Cart

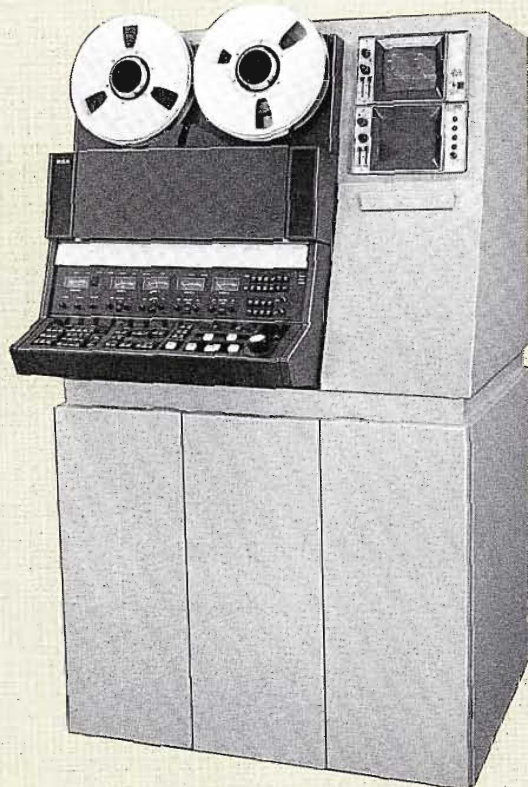

Compact Console



Studio Console

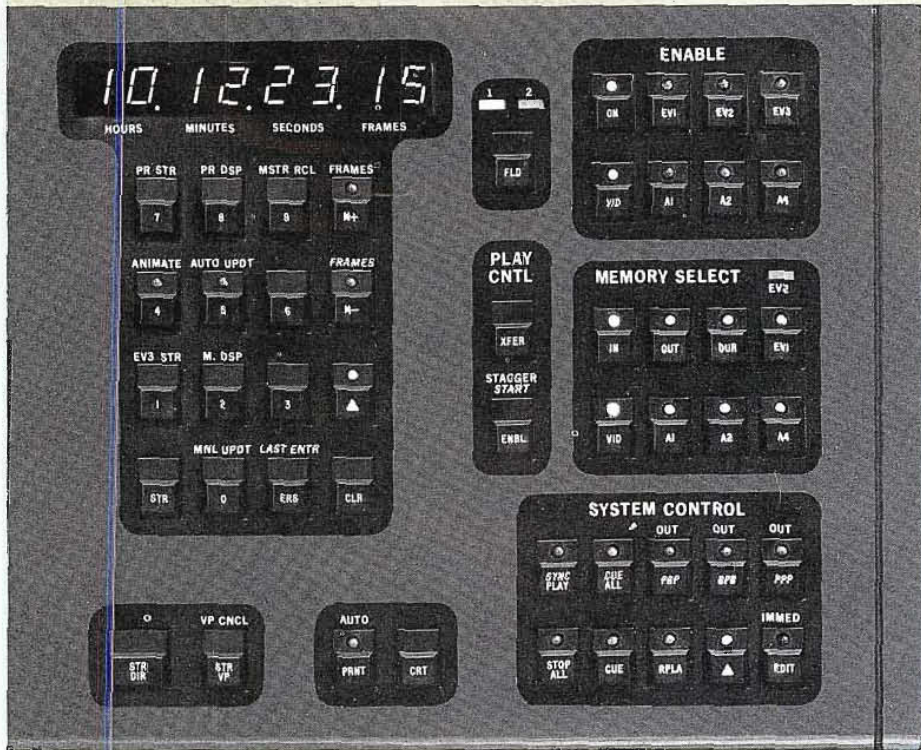

Functional layout of the AE-800 Control Panel permits easier editing.

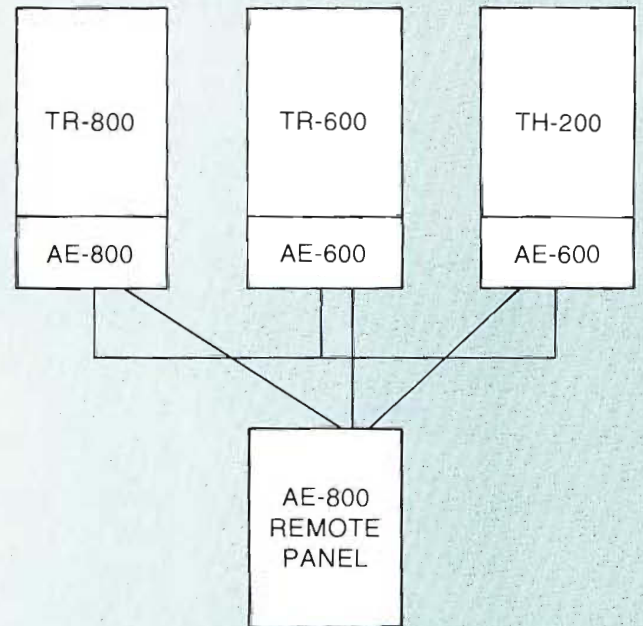

The AE-800 Editing System is compatible with AE-600 Systems, permitting an intermix of tape formats.

### AE-800 Time Code Editing System

This major editing system developed in conjunction with the TR-800 offers features that take advantage of that machine's unique capabilities, including synchronization of playback machines at variable speeds, in forward or reverse.

The AE-800 is a sophisticated, easily mastered system. Its extensive capabilities and features are designed to encourage productive editing sessions without inhibiting creativity.

The edit capability of the AE-800 includes split audio-only; video-only and audio/video edits. The system has six different preview modes, and up to four independent edits can be made on the same tape pass. Complete lockup, color framing and synchronization of all VTR's in the system takes less than four seconds. The system has the capability of selecting edit points to field accuracy, doubling the resolution of frame-accurate editors.

### AE-800 System Configurations

AE-800 editing system electronics are integral to the TR-800, and systems can be supplied with Local or Remote Control Panels as required. One Record and up to eight playback machines can be controlled by the AE-800. Any one of the TR-800's in a system can be designated as the Playback or Edit machine. Any or all of the playback machines can be delegated for use in the editing system. Playback machine delegation is made from the keyboard of the control panel of the Edit machine.

### Functional Control Panels

Careful attention was given to the layout of the AE-800 Control Panel. The Keyboard Display and Data Entry keys are clustered and grouped by major functions to accommodate a wide range of editing functions.

The Remote Control Panel is even more compact, with a single rack-width panel providing controls for up to three AE-800-equipped VTR's.

Informative CRT displays are provided at the Local Panel and Remote Control Panel locations, with hard copy print-out as an available option.

### Compatible With AE-600 Editing Systems

Another significant advantage of the AE-800 system design is its compatibility with AE-600 Time Code Editing system. This facility permits an intermix of the 1-inch TR-800 and the 1-inch TH-200 VTR's, as well as the quadruplex TR-600A tape machines in a system. Since any configuration of AE-equipped machines can function with full compatibility, added flexibility is provided for editing systems already in operation. Adding the AE-800/TR-800 system to existing AE-600 editing facilities extends the useful life of such systems and expands their performance capabilities.

# NEW BRIGHT SOUND: NEW ALL-SOLID STATE 5kW AM TRANSMITTER

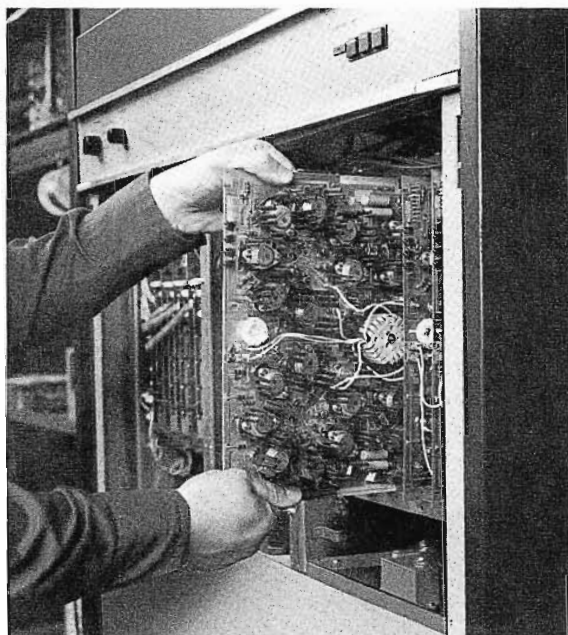

RF Amplifier Section

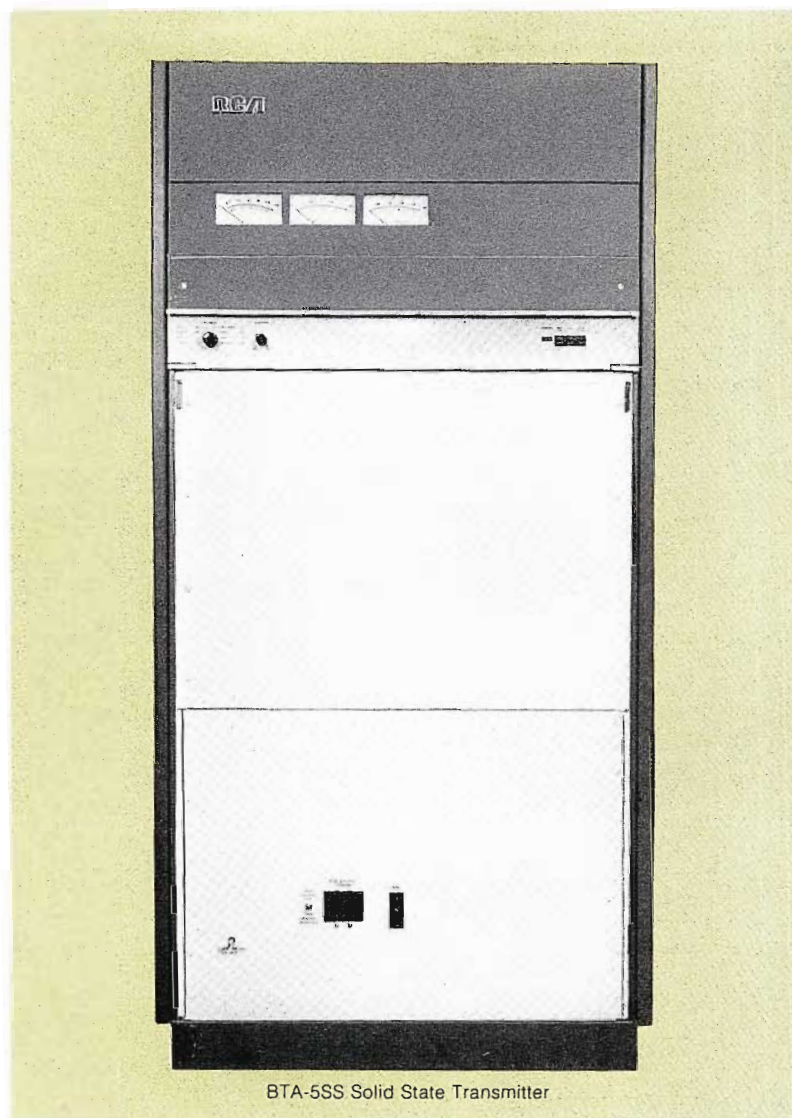

BTA-5SS Solid State Transmitter

The BTA-5SS is solid state from the exciter input to the output transmission line. It is a state-of-the-art AM transmitter that is lightweight, easy to install, and which features notable improvements for higher efficiency, reduced maintenance, and enhanced reliability. Its new bright sound results from the extended audio signal performance achieved with a new modulation technique—Pulse Linear Modulation.

The new system is stable, requires minimum maintenance and rarely needs tuning. It is capable of 125% asymmetrical modulation at full rated power and was designed to adapt readily to stereo operation.

#### Compact Cabinet

The BTA-5SS is self-contained in a single cabinet which offers maximum accessibility and convenience for operation and maintenance. Cabinet dimensions are 36" wide, 77" high and 30" deep (91.4 × 195.6 × 76.2 cm). Since no access is required from the sides of the cabinet, the transmitter may be flush-mounted against the wall on either side. Power, remote control and audio

connections are made through the top of the transmitter or through the base as preferred.

#### Pulse Linear Modulation System

The modulation system utilizes a highly refined pulse width modulation (PWM) technique called Pulse Linear Modulation (PLM) and consists of a modulation generator, modulation driver, four parallel modulation amplifiers, a subcarrier filter, offset supply, phase correction equalizer and pulse stretcher.

The Pulse Linear Modulation system provides low distortion, audio frequency response from 20 Hz to 12 kHz, fast transient response, and high modulation levels. It also provides a convenient method of adjusting and regulating carrier output power.

#### RF Section

The RF section of the transmitter consists of the RF Generator, RF pre-driver, RF driver amplifier and six Class D modulated bridge power amplifier trays. Special bridge circuits allow the transistors to switch at frequencies previously unattainable in high power solid

state design. The efficiency of the parallel RF bridge amplifiers is greater than 80%, allowing overall transmitter efficiency of 60% or greater.

The operational reliability of the BTA-5SS is enhanced by its ability to tolerate the loss of individual power transistors. This means that even if some RF output transistors fail, the transmitter will continue to operate with little or no reduction in output power.

#### Factory Tuned and Tested

The BTA-5SS is designed to operate over the extended AM band of 525 through 1705 kHz. The range of matching is unusual, with the entire AM band broken into only three ranges of 525 to 800 kHz; 800 to 1200 kHz to 1705 kHz. A change of frequency within one of these bands does not require a change of any major components to tune the transmitter.

The transmitter will be tuned and tested at the factory on a specified frequency and shipped ready for operation. Installation of the basic transmitter typically takes a matter of hours, eliminating costly assembly and wiring time. □



# Cameras In The News

## ON THE SET IN SEOUL

Three TK-47 cameras with "Autocam" have been in regular use in the modern television complex of Tongyang Broadcasting Co. Ltd. in Seoul, Korea. The fully automatic studio cameras are a major updating of program production facilities for the Channel 7 broadcast center.

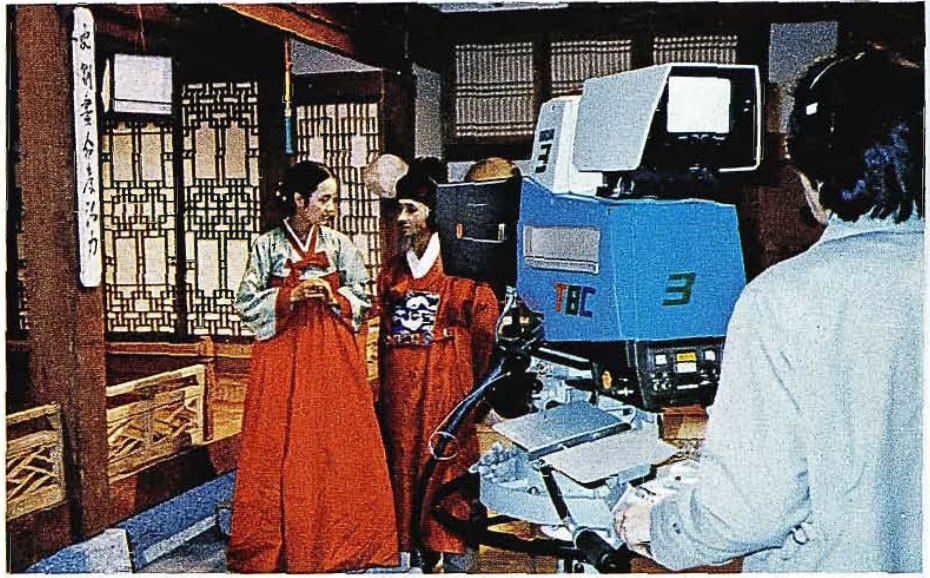
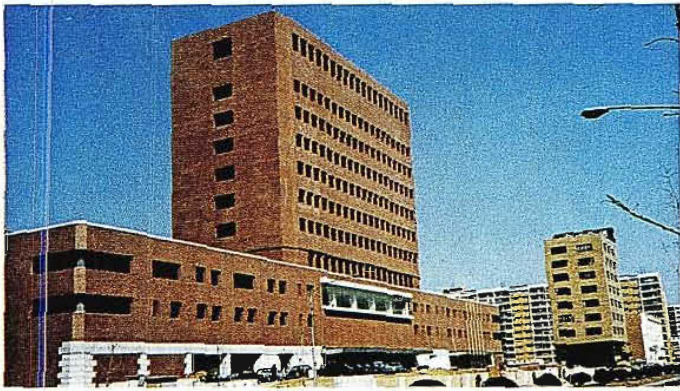

## LAND AND SEA AND AIR



On A Yellow Submarine And A Yellow Land Machine. TK-76 cameras ride aboard a racing car and mini-submarine.



Channel 80, an independent French teleproduction company, gives its TK-76 and TKP-45 portable cameras rugged performance tests on a variety of production assignments. Usually the cameras operate from Channel 80's well-travelled mini-mobile unit.

Three production assignments are pictured here, with cameras covering action involving land, sea and air craft.

**Aviation History—A "Then And Now" Story.** A magnificent supersonic Concorde jet looks over its forerunner—a World War I vintage airplane, as Channel 80's TKP-45 cameras record the contrast for a television production.



## BICYCLE RACES IN GERMANY

At a major bicycle race in Frankfurt, TK-76 cameras precede the contestants, capturing crowd scenes to flavor the drama and excitement of the competition itself. For ground-level action, the door of the vehicle is removed, giving the camera a clear view. Recommended only for the most intrepid of camera operators.



## THREE FOR RVN/AMV—AUSTRALIA

The RVN/AMV Network has markedly increased its capability for local production with the addition of three TK-76 cameras.

RVN/AMV covers the South West and Riverina areas of New South Wales and the North East area of Victoria. While normally deployed independently, the cameras can also be operated as an integrated 3-camera production system, using a mobile van equipped with camera controls and complete video/audio facilities. Pictured are RVN/AMV Chief Engineer, Jeff Meyer and cameraman Bob Draper.



**"COLOR MACHINE"  
DELIVERS THE NEWS—  
AND MORE**

TVW Channel 7, Perth, Western Australia, uses "The Color Machine"—a van equipped with a TK-76 camera and BCN-20 portable VTR—for news, sports and documentaries.

Greme Hunt, News Editor, notes that the TK-76/BCN-20 combination has been used most effectively for sports coverage where previously cameramen were forced to overshoot film so as not to miss any action.

Picture quality on sporting assignments is far superior to that achieved with film, he adds.

The ENG system is particularly suited to remote news coverage—such as in the "out-back" country in the far north of Australia—where deadlines would not allow time for processing editing film. After flying to and from the assignment with the TK-76 and BCN-20, the crew can preview the tape in "The Color Machine" van while travelling between the airport and the station, marking times on a cue sheet. Editing is then achieved with a minimum of delay.

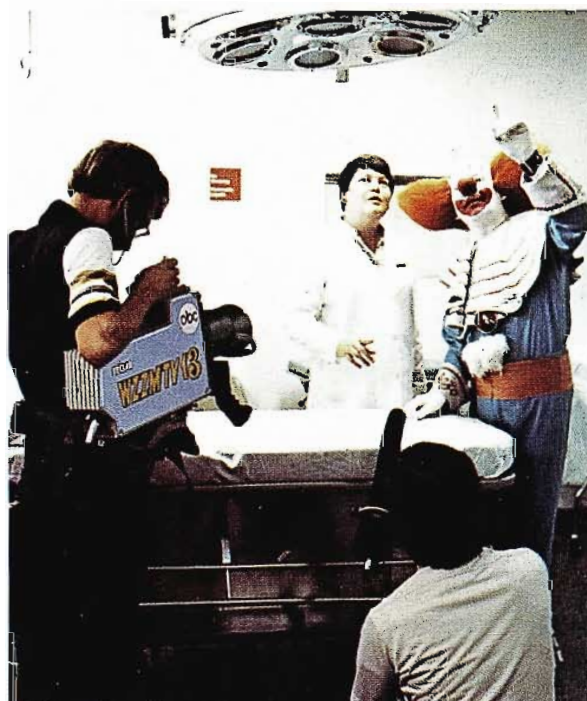

**TK-76 PASSES VERSATILITY TEST  
AT WZZM-TV**

Five TK-76 cameras at WZZM-TV, Grand Rapids, Michigan, provide effective news and sports coverage for the Ch. 13 News Department.

The sixth camera handles documentaries, public affairs programming and commercial production for the station, demonstrating the versatility of the TK-76 for ENG and EFP assignments.

Alan Hartwick, Public Affairs—Commercial Photographer for WZZM reports on a "typical" assignment in the Gulf of Mexico while taping a public affairs documentary on the Michigan-Wisconsin pipeline. "The camera survived the worst humidity I've ever experienced. The temperature on the natural gas rig was 96 degrees; the relative humidity was 92%. The camera had spent 15 hours prior to that in an air conditioned room."

A locally produced program using the TK-76 is the "Bozo Saturday Special", a half-hour on-location program with Bozo visiting places of interest to children.

Another WZZM-originated children's program, "When I Grow Up", represents an excellent utilization of ENG/EFP, according to Mr. Hartwick. This production, in which the child acts out his career role, is produced by a two-person crew: a cameraman and a producer who also handles audio.

One versatile TK-76 Camera is providing WZZM-TV Public Affairs with a lot of production capability—and they are making the most of it.



PACIFIC VIDEO  
POST PRODUCTION CENTER  
Makes An Impressive Debut

Master Control is an exotic, functional area which provides centralized system control and full accessibility to the equipment components.



The Client Lounge area reflects the modern look of Pacific Video, and the use of attractive surroundings to enhance creative productivity.

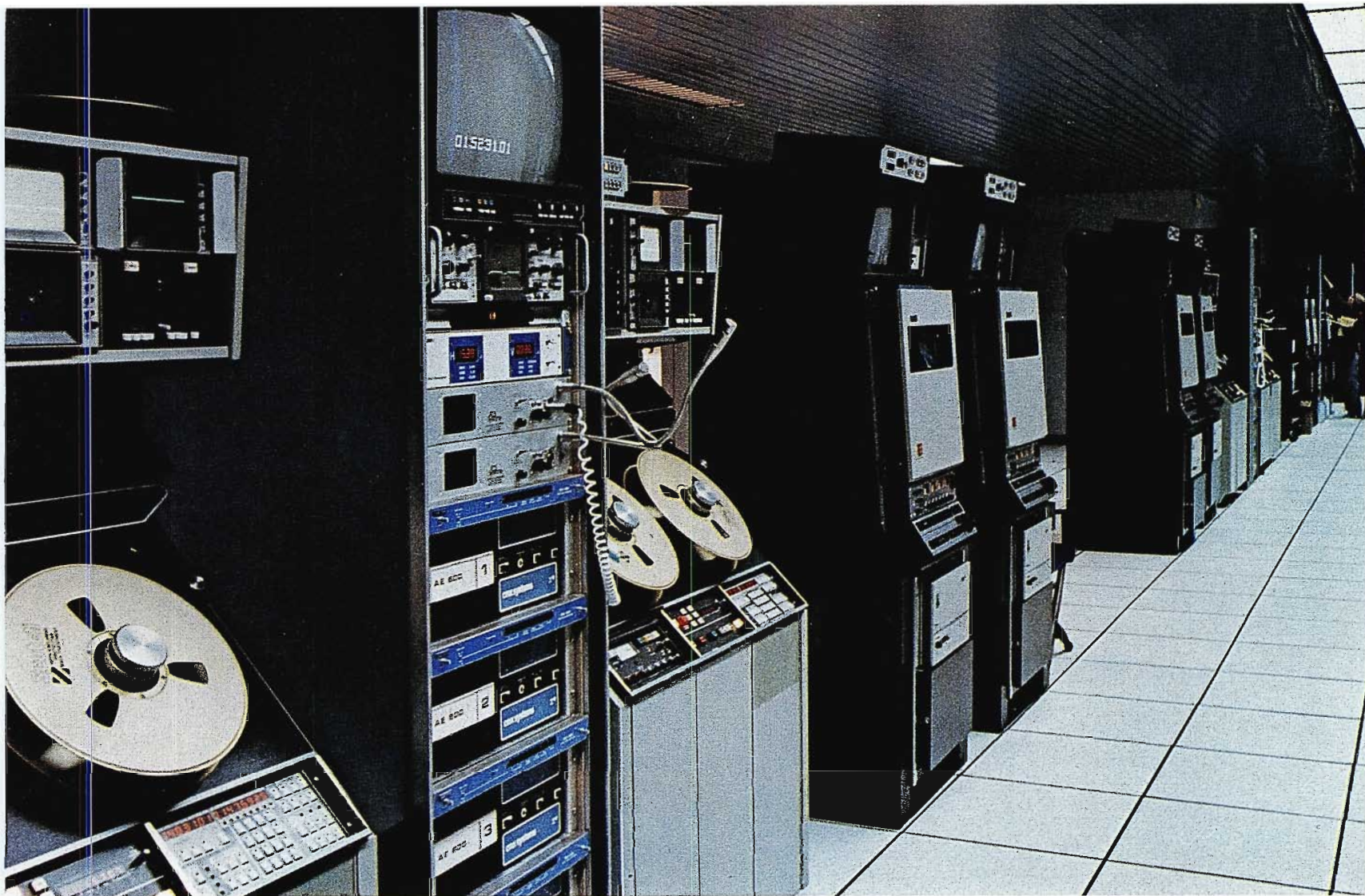

Extensive video tape capability is evident in this long line of VTR's at the Pacific Video Post Production Center.

**IMPRESSIVE** . . . is an understated one-word assessment of the new Pacific Video Post Production Center in Los Angeles. It is a glittering 20,000 sq. ft. state-of-the-art facility designed and equipped to take advantage of the latest technology, yet providing the client/editing team with a comfortable, efficient creative environment.

The Pacific Video equipment array is impressive. The complement of video tape machines includes six RCA TR-600A quad machines with AE-600 editing systems; eight TH-100 Type C 1-inch VTR's; two TH-50 portable 1-inch units, and a dozen ¾-inch cassette recorders. Four CMX-340 computer editing systems are installed, supported by other major equipments: an ESS-2 Digital Slow Motion/Still Store system; a DVE-5000 Digital Video Effects System; two Vidifont graphics systems, and audio and video switchers for each of the three large editing suites. Rounding out the capability equipment listing is a sophisticated audio recording/sweetening room equipped with an automated, computer-controlled console; two 24-track recorders; four 4-track recorders, and four 2-track units. An

insert/sound stage for audio recording and single camera commercials adjoins the audio sweetening room.

#### Editing Versatility

Even more impressive than the hardware is the versatility and sophistication of the overall teleproduction plant. Editing versatility is a prime example. At Pacific Video, quad, 1-inch and ¾-inch cassette video tapes can be intermixed and mastered on any desired tape format. Direct edits can be made in the different formats without the need for dubbing up or down and losing a generation. In addition, two tape masters in different formats can be made simultaneously.

#### First: A Successful Mobile Unit

Planning for the Pacific Video Post Production Center started soon after Pacific Video Industries launched its mobile TV production unit in 1972. The management organization then included Jack Meyer, Seymour Meyer and Randy Blim, and the operation quickly met with success.

Even as the mobile production unit rolled up a prestigious list of credits and built a solid reputation for quality

performance, plans for expanding into post-production were being formulated. The timing for moving into the new venture was a matter of observing the trend toward video tape and of acquiring financing for a top-rank facility.

#### From Two Empty Warehouses—A Dream Comes True

In 1979, the dream became a reality, with the opening of the Pacific Video Post Production Center, with the same management team in place. While the new facility is a showcase of electronic marvels and unique capabilities, the bottom line remains the same—performance. And the success pattern fashioned by the mobile TV production unit is being repeated at the new post production facility.

The present attractive Pacific Video facility presents a remarkable transformation of two non-descript warehouses, and is a tribute to careful planning. Basic floor plan layouts were developed following an extensive year-long study of existing post-production facilities.

Once the site was set, construction and implementation of the technical plant proceeded rapidly. Jack Meyer, Presi-

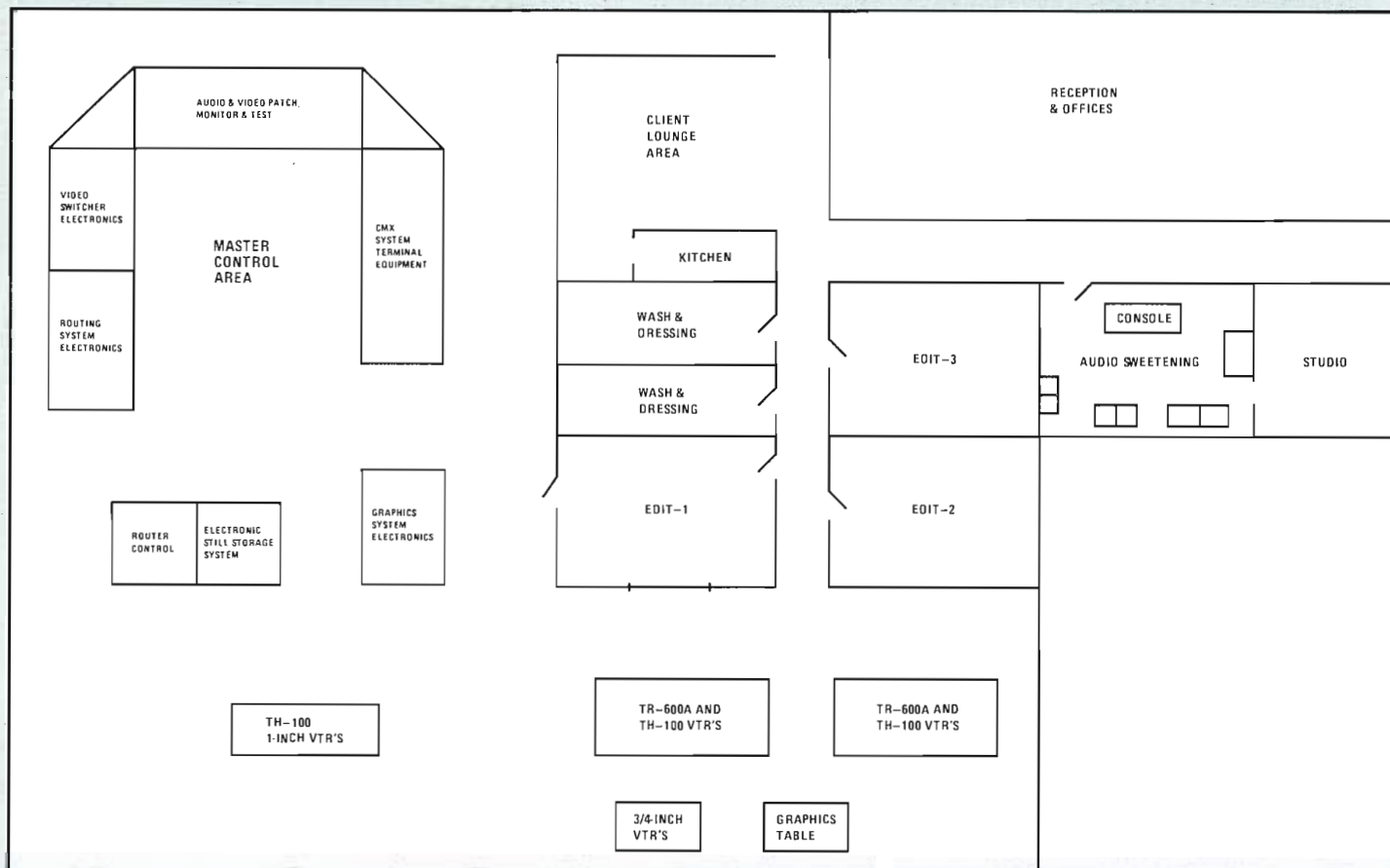

**PACIFIC VIDEO POST PRODUCTION**

dent of Pacific Video sums up the effort and the results:

“We started with two warehouse buildings with bare walls and completely refurbished and transformed them into a state-of-the-art post production center in a matter of months. Editing Suite “A” went on-stream in April 1979. The second suite opened in May, and the third in July. We’ve been operating two full shifts ever since, 18 hours a day, six days a week—and still have the capability of expanding both our facility and our staff.”

**“The Timing Is Right”**

Another key participant in getting the new post production facility on-stream is General Manager Bob Bardo, who came to Pacific Video from ABC-TV where he was in the operations division and a director of the network’s unit management team. “The timing is right,” he notes. “The trend to tape accelerated rapidly with the introduction of broadcast quality 1-inch machines, and the adoption of the “C” format as standard has changed industry production patterns. It means that program material can be taped in the studio and on location, using both quad and

1-inch tape, and mixed in post-production without sacrificing quality.”

**Emphasis On Creativity**

At the new Pacific Video Production Center, the emphasis is on the creative aspects of the client’s assignment, with the editing functions occupying center stage, isolated from the hardware and technical operations.

The concept is well articulated by Randy Blim, Vice President and Director of Engineering, who was also responsible for its implementation. “Our concept simply was to remove all of the technical harassment that has surrounded post production operations. For example, the client should be concerned with how the picture looks on the monitor. The tape format, the computer system in use, the electronics and signal-handling systems in the plant need be of little consequence to him.”

This concept has been effectively carried out in the Pacific Video facility, where the Editing Suites and the Audio Sweetening Room are physically separated and isolated from the Master Control area and the banks of video tape machines. Only remote control functions are located in these rooms. In ad-

dition, this arrangement has resulted in simplified cabling and a precisely timed system.

**Three Identical Editing Suites**

Three large editing suites are now in operation, and are identical in size, in equipment layout and in acoustical treatment. Only the decor and wood treatments change from room-to-room.

Pacific Video assigns an editor to each Editing Suite, and the editor has a video tape operator working with him. The video operator loads tape and maintains quality checks to assure optimum results. In addition to test facilities at each tape machine, a readout in the Editing Suite above the switcher shows an LED display of Horizontal and Vertical Blanking to give the editor still another indication of the output quality.

The editor works with the client in setting up edits, and performs the technical operations: establishing edit points on the CMX-340; operating the audio board; the Digital Effects system; the video-switcher; the graphics system; and the Still-Store/Slo-Mo System.

**Determining Equipment Complement**

Arriving at the equipment complement

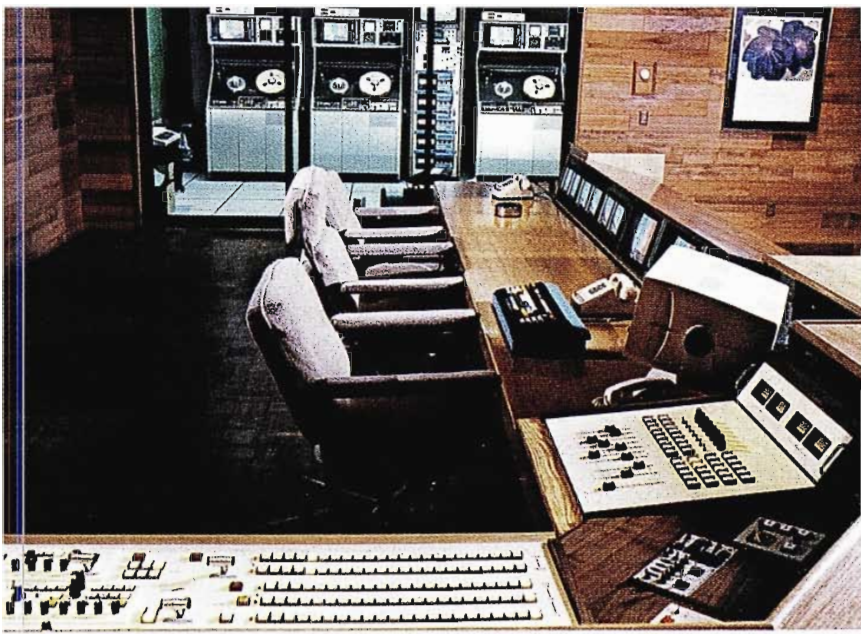

Editing Suite #1 is spacious, comfortable, and bristling with sophisticated editing facilities. Video tape machines show through a picture window in the background.



Randy Blim, Vice President and Director of Engineering, operates the CMX keyboard in one of the Pacific Video editing suites.

for Pacific Video Post was a two-step process, explains Mr. Blim. "First, we investigated the range of products needed to set up the post-production center. Then came the more difficult process of making economic projections to determine what kind, and how much equipment should be purchased in order for the facility to become profitable in the shortest period of time.

"As with most business decisions, economics dictated what was going to be installed. The final equipment list was calculated by knowing how much each piece of equipment could be billed per hour, and figuring out how much return could be obtained from the investment.

"We found that the expense of building one editing room was extremely high because of the initial investment in basic computer editing, audio and video switching, support systems and terminal equipment. We projected the cost for a second and third editing suite and found that this last combination would meet our criteria for achieving break-even and profitability in the shortest time frame. We also gambled (and guessed right) that the 1-inch Type C format would be the new video tape standard. With the widespread use of 1-inch tape

for production, stereo television is almost inevitable. For this reason, a two-channel audio system is used throughout our entire plant."

#### **Tape Intermix Capability— No "Lost Generation"**

"The Pacific Video facility is designed to handle today's tape requirements and those of the future," Mr. Blim continues. "Quad is established and trusted, while 1-inch is a rapidly growing format. Production people are splitting productions—doing master recordings on 2-inch tape, but also doing a lot of isolated recording and location work on 1-inch. In most post production houses it is necessary to dub the 1-inch to quad before editing. We took a different approach to eliminate this lost generation of quality. The Pacific Video system is designed to permit intermixing all three formats—1-inch Type C; quad; and 3/4-inch. We can do it with complete flexibility. Any mix of tape machines can be assigned to any editing suite, and each format can be handled in real time.

"The only limitation is the pre-roll time required by the slowest machine. The AE-600's are capable of working on a 3-second pre-roll, while the cassette

format requires a 7-second pre-roll. This is typically not a problem, since most people tend to work at 5 and 6 seconds anyway.

#### **Tight Demands Set For Tape Machines**

"The decision to go with RCA for our tape requirements was based on the involvement of our two companies from the time we built our mobile unit in 1972. It was not only a matter of faith in the product—but more than that, faith in the company and the people as well. We knew that RCA wanted our system to be as good as we wanted it to be.

When it came time to build the post production facility, we had some very tight demands—very high standards that we want to meet in quadruplex recording. Multiple generation quality is an important consideration, and we require picture quality that is excellent at the sixth generation as well as the first.

We evaluated competitive machines and determined that the TR-600 with the modifications that we specified met our requirements. A similar evaluation was made for the 1-inch Type C VTR's and resulted in our selection of the TH-100 and TH-50 machines."

All six Pacific Video TR-600's are equipped with the AE-600 time code editing systems; fast shuttle, and wide band video filters, as well as all of the Time Code Accessory options.

Since the AE-600 is a microprocessor-based system, it can interface directly with the microprocessors in the CMX-editing system. And it provides a complete back-up editing system, since the AE-600 can do machine-to-machine editing as well as two or three-machine editing if required.

"Including the one-inch Type C tape machines as an integral part of our facility from the start has been extremely advantageous," Mr. Blim affirms. "At present, we are doing as much editing in the one-inch format as in quad. One-inch tape establishes a method of editing that we haven't seen before—providing us with a picture that is continuous. Whether the machine is in fast forward or in rewind, we now have continuous video information all the way through the reel. It's like looking at a film on the "Moviola"—no matter how fast you move the reel in scanning for one particular piece of information, you can see the picture at all times, so you can stop the machine at the exact desired point."



Four TH-100 one-inch VTR's in a separate group are used as auxiliary playback machines.

### A Long Line Of VTR's

The quad and 1-inch video tape machines are lined up in an extended line, divided into three operating groupings:

Two groups of 3 TR-600/AE600 quads and 2 TH-100 one-inch

One group of 4 TH-100's

This configuration of machines was planned to break up the amount of traffic that might occur if the machines were clustered. By spreading the machines and intermixing the quad and 1-inch, Pacific Video achieves better work flow and better control of the machines, as well as lessening the possibility of misplacing client tapes. The four separate 1-inch VTR's are used as auxiliary playback machines.

The middle group of VTR's is visible through the window of Edit Suite "A", permitting eye contact if desired. However, Mr. Blim notes, this arrangement is a matter of tradition rather than necessity.

### Editing Suite Design

The editing suites are much more spacious than customary facilities. They are set up on two levels, with the operating positions on a raised platform. The lower level provides room for additional client and production personnel who are not directly involved in the edit decision-making operation. This arrangement eliminates the distractions of people and conversations behind the director/editing team.

The key people in the editing session—director and editor—are located in the center, visually and acoustically the

best part of the room.

"We wanted to be sure that all of the rooms were visually and acoustically correct," Mr. Blim explains. "The Monitors in each of the Edit Rooms are all critically placed at the right angle and height to maintain the proper sight levels to minimize eye strain. Speakers are placed on their axes for average height of hearing and are placed in a certain position in the room.

"Myles Weiner of Arrowhead Engineering was our chief consultant. He worked with us on acoustical design, and was responsible for the double-wall construction for sound isolation: the ceiling designs; the acoustical treatments in all of the editing rooms. It was his responsibility to make sure that all three editing rooms would acoustically sound the same."

The editing suites were laid out for production operations, with ample desk space at the left of the director and editor for script people and assistants. On the table, directly in front of the editor is the CMX terminal and editing keyboard. To the right is the audio console, then the controls for the Quantel digital video effects system. Next is the video switcher, the Vidifont keyboard, and the ESS-2 Still Store remote operating controls.

Underneath these last three table-top units three short racks of equipment that house all of the electronics necessary to make the Editing Suite itself function. The electronics for the video switcher, audio console, DVE and CMX systems are located in Master Control, outside

of the Editing Suites. Since there is no hardware in the room, if anything should fail, trouble-shooting can take place at the source, without the client being aware that there is a problem.

### Sophisticated Computer Editing and Routing Systems

The CMX-340 editing system and the Image Video routing system are responsible for keeping Pacific Video's electronic complex operating smoothly and efficiently, according to Mr. Blim.

"The CMX-340 is currently the only editing system available that interfaces with all tape formats—which makes it the most flexible for us. The CMX system is basically one or more 'executive' computers which communicate with a number of smaller computers. CMX refers to these as I<sup>2</sup> (Intelligent Interface). In our editing complex, there are four 'executive' computers which serve the three editing rooms and Audio Sweetening.

"All VTR's in our plant have a dedicated I<sup>2</sup>, each of which is capable of communicating with the 'executive' computers. In addition to the quad, 1-inch and ¾-inch video tape machines, the audio facilities—24-track, 4-track and 2-track machines—are also under CMX control."

### Quad And 1-Inch Masters—Simultaneously

"The CMX system is designed to handle up to seven tape machines. Our system provides the capability for having six playback machines and a record machine, or five playback machines and two record machines.

"This means that we can edit a 1-inch and a 2-inch master simultaneously, regardless of the tape format used for editing. We can build two first generation masters side-by-side."

### Multi-Tape Editing Via "Sync Roll"

A production method that is becoming increasingly popular is that of using isolated cameras with dedicated tape machines, with switching done later at an editing session. In handling shows, such as situation comedies, for example, four cameras may be used, each with its own tape machine. Tapes from each of the cameras can be loaded on the tape machines at Pacific Video and played back in sync on the editing system, using a program called "Sync Roll".

Using a CMX keyboard the director can switch the taped show as though it were a live production. Using the video switcher in an Editing Room, the show





Another fully-equipped Editing Suite, with its own distinctive decor and rich wood panelling.



Quad and one-inch VTR's are grouped for better workflow.

can be put together in sequence, building the edit decision list as the tapes roll.

In rolling all four tape machines in sync, the director is looking at four monitors, as he does when the show is on live. As he views the tapes rolling, he can issue the same directions that he would for the live production: "Ready One" . . . "Take One" . . . "Ready Two" . . . "Take Two", etc. With this technique, the entire show can be cut at one sitting, building a complete list and providing the edits for a master in real time. From here it is a simple matter to check the work master tape and say "I want to replace the fifth edit with another shot". "Sync Roll" permits doing that quickly and accurately, by rolling all of the tapes back to the exact scene.

#### "Zero Time Plant"

Timing for the Pacific Video electronic complex was a major consideration in system planning. Randy Blim describes the system.

"In order to maintain consistent quality with picture and sound—even with the large number of machines involved—we needed to build our plant timing system as perfect as it could be, so the operators would have the least number of adjustments to make. Our goal was a "zero time plant" where system phase, subcarrier phase, the differences in video levels—pedestal and sync and burst; set-up and chroma—can all be maintained consistently."

"With a zero time reference for the plant, once a signal arrives in time and

phase, it can be distributed to every tape machine in the building via the routing switcher. Each tape machine has its own input selector and can select any output from the routing switcher. This facility permits directly accessing any piece of equipment or any other tape machine, or any editing suite, or the output of the studio *directly* into any selected tape machine for recording.

#### Two Routing Switchers

"The main routing switcher (50 × 48) is designed so that four levels—video; time code; Audio 1 and Audio 2—can all be broken apart separately, and each one of those levels can be selected independently. You can take the audio from one machine, time code from another, and video from the third machine"

Tied to the main router is another routing switcher that has 40 inputs and 24 outputs. This router is unique in that it has a five-level matrix, and also is timed, all inputs to all outputs. In addition to the four channels noted above (video; time code; Audio 1 and Audio 2) this router matrix includes a fifth channel that controls data communications between the computer editing system interface of each tape machine and the CMX "executive" computer. (Each Editing Suite has its own dedicated "executive" computer.)

The crosspoints of the second routing switcher are totally independent of the main router. They are serially communicating with each other, so each one knows the status of what is being selected by the other router. The smaller routing switcher's sole purpose is to as-

sign tape machines to editing rooms. Select the output of a machine and it shows up in that editing room, ready to go. All the operator has to do is to physically place the tape on the machine, align the machine and establish standard levels, and wind the machine for playback. From there, the system will take care of getting it to the selected editing room.

#### A Fully Integrated System

The second routing switcher takes a given tape machine and, when selected to an editing room, assigns the video coming from that VTR to a primary cross point of the production video switcher in that room. The video arrives at the right level, right time, and right phase. At the same time, the audio output of that tape machine has been assigned to the input of the audio console in the same room, at the right level and in the right phasing. Similarly, the time code is assigned to a character generator that displays time code on a picture monitor in the selected editing suite, as well as in Master Control. At the same time, the CMX interface (I<sup>2</sup>) for that VTR is selected and assigned to the proper "executive" computer.

"With this fully integrated system," Mr. Blim explains, "at the push of one button, we can assign the audio, video, time code and the serial data communication for a tape machine to a given editing room. That tape machine is ready to go. If at any point during the editing process you want to change to another machine—to go from a quad to a 1-inch VTR, for instance—all you have to do is to re-assign the routing



Each tape machine has its own input selector and can select any output from the routing switcher. The result is virtually unlimited flexibility in utilizing equipment.

switcher and the CMX is all set to go for a different type of tape. Or, if a machine should fail and you have downtime, you can take the tape from one 1-inch machine and move it to another; then walk to the routing switcher and dial in the change—"delete VTR-9 and switch in VTR-10". Done, and you're back in business again that quick."

#### Master Control—Exotic and Functional

Master Control at Pacific Video Post looks like a scene from the movie "2001". The horseshoe-configured control center, with its seemingly endless line of racks pulsates its electronic beat. Batteries of monitors show bright displays of pictures, color bars and graphics. Rows of LED's and digital readouts continuously blink status messages. Reflected lights glint from the chromed ceiling, mirroring the colorful panorama below.

There is, however, one wistful reminder that humans are indeed a vital part of this electronic cosmos: A plaintive, hand-lettered sign above an opened tray of modules reads "Dear God, let it be a fuse".

According to Randy Blim, the exotic appearance Master Control just happened to work out that way.

"Initially the layout was designed to be engineering functional—to make every piece of equipment accessible from both the front and the rear for easy installation, removal and rearrangement. The whole room rests on a computer floor—

so all cabling is easily accessible. You can re-wire and make changes in patch bays and configurations throughout the entire building very simply.

"The horseshoe rack arrangement is functional in that it provides a central location for all of the electronics of the routing switcher and for the production switchers; also all video and audio patch bays and all of the CMX editing systems—all grouped in one central area.

"That means that in order to time the plant, cable distance from the routing switcher to the production switcher is very short; therefore we can make those cables precisely the same length and maintain very accurate timing and phasing and very accurate signal loss—hardly any signal loss, in fact. We don't have to run coaxial cables 300 feet to a piece of electronics.

"We just run a remote control cable from Master Control to each of the Editing Rooms. Only the remote control functions are located in the Editing Rooms."

#### Audio Sweetening And Studio/Soundstage

Recognizing the increased emphasis on audio in video tape post production, Pacific Video planned its facilities accordingly. All of the sound facilities are stereo, including the sophisticated audio sweetening room. This handsomely appointed space is equipped with a custom computer-controlled audio con-

sole, with 48 inputs and 32 outputs; automated fader and mute functions and all of the other "bells and whistles" for top quality recording, editing and sweetening full stereo.

Tape equipment includes two 24-track recorders; four 4-track recorders; four 2-track units, and a complement of cartridge machines. One of the CMX editing systems is interfaced with the console and the audio machines in the sweetening room. There is also one of the TH-100 VTR's assigned exclusively to this area.

Adjoining Audio/Mixing is a studio/soundstage—26' x 39', with a 17' ceiling. This is used for making original sound recordings; for overdubs; for dialog re-recording— or as a one-camera insert stage. A TK-760 camera is used for handling commercials, color graphics or stand-up chromakey scenes. Lighting is film style, from the floor.

The successful launch of the Pacific Video Post Production center has accelerated plans for expansion of the facilities. The next phase, already being implemented, is the installation of telecine and color correction systems for handling film-to-tape transfers. Two off-line editing suites are also being added.

#### People Are Still The Key

With all of the technical achievements and esthetic design concepts that went into the development of Pacific Video Post, Executive Vice President, Sey-

The Master Control arrangement provides a central location for all of the electronics of the routing switchers; the production switchers; video and audio patch bays, and CMX editing systems.

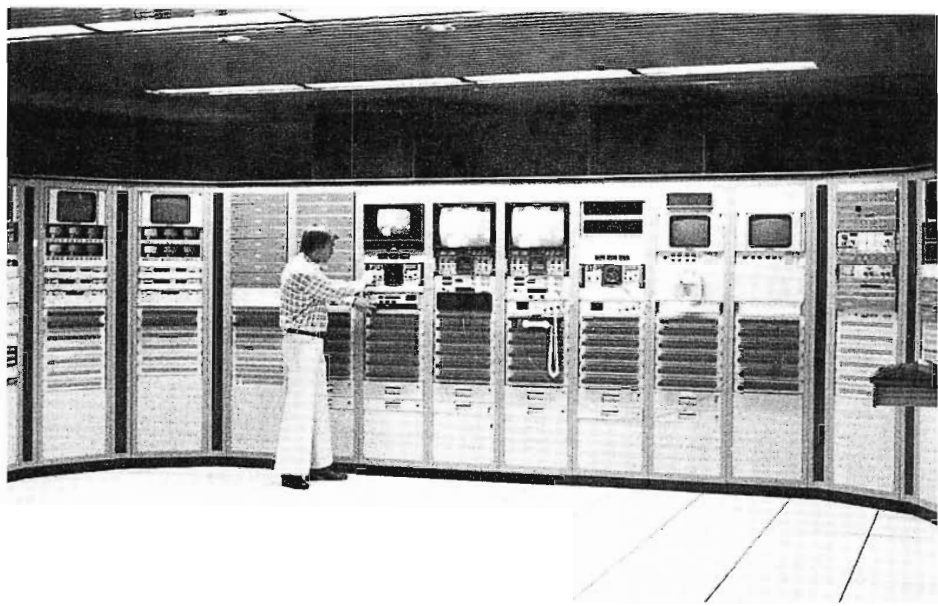

mour Meyer is quick to point out that "Your people are still your key to a successful operation." He continues, "We spent as much time selecting the personnel for our facility as we did selecting equipment and planning the layout of the building. In fact, many of the design concepts, both technical and esthetic, were a result of trying to make the facility comfortable and workable for the people who have to run it."

**Video Outlook Is Bright**

As its current business rolls forward, Pacific Video Post sees an even more important role for video in the years ahead.

Jack Meyer has no doubts about where the teleproduction industry is going: "We're into the tape revolution," he emphasizes. "Film people are moving into tape. In the next ten years everything will be electronic."

"Video has always followed the film industry," Randy Blim affirms, "but we are becoming more attuned to the reasons why film people do the things they do. We're learning their lighting techniques; their photographic style—and now we're adapting their special effects techniques. What film makers have been doing optically in a film lab—wipes, dissolves, keys, mattes—we're doing electronically. And we're doing them faster and more economically."

"Among our long-term goals is demonstrating to the film industry that video tape is a viable production medium. The continuing development of video is extremely important to us because at Pacific Video Post we have made a total commitment to that medium."

With its talented staff, state-of-art facility and proven performance record, Pacific Video may well achieve that long-term goal quickly. □

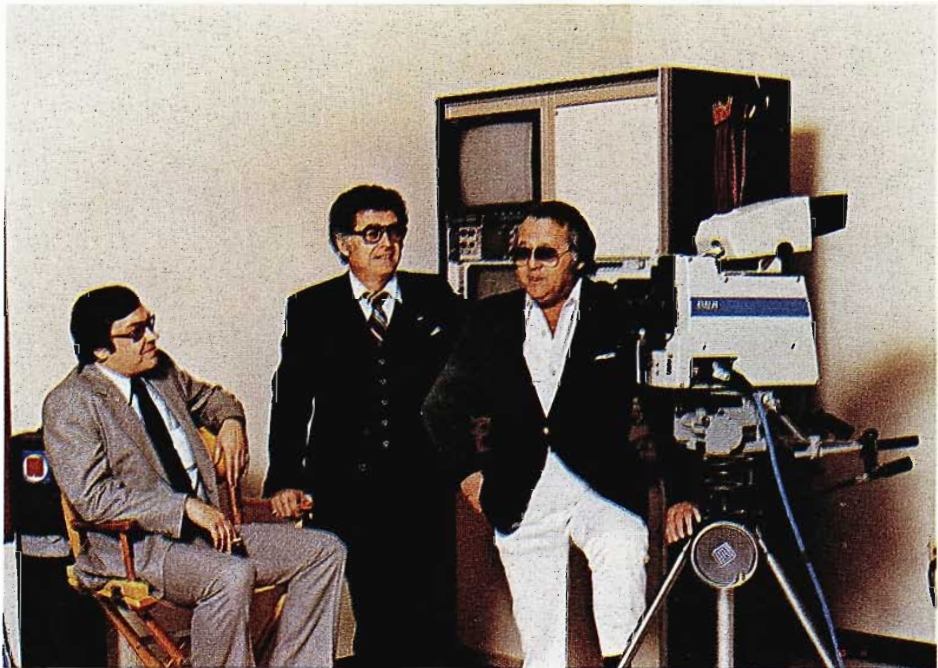

President Jack Meyer (right); Vice President Seymour Meyer, and General Manager Bob Bardo (left) strike a rare relaxed pose with a TK-760 camera in the Pacific Video Post Production Center.



Sophisticated Audio Sweetening Room includes a custom computerized-controlled audio console. A window in the background provides a view of the soundstage.

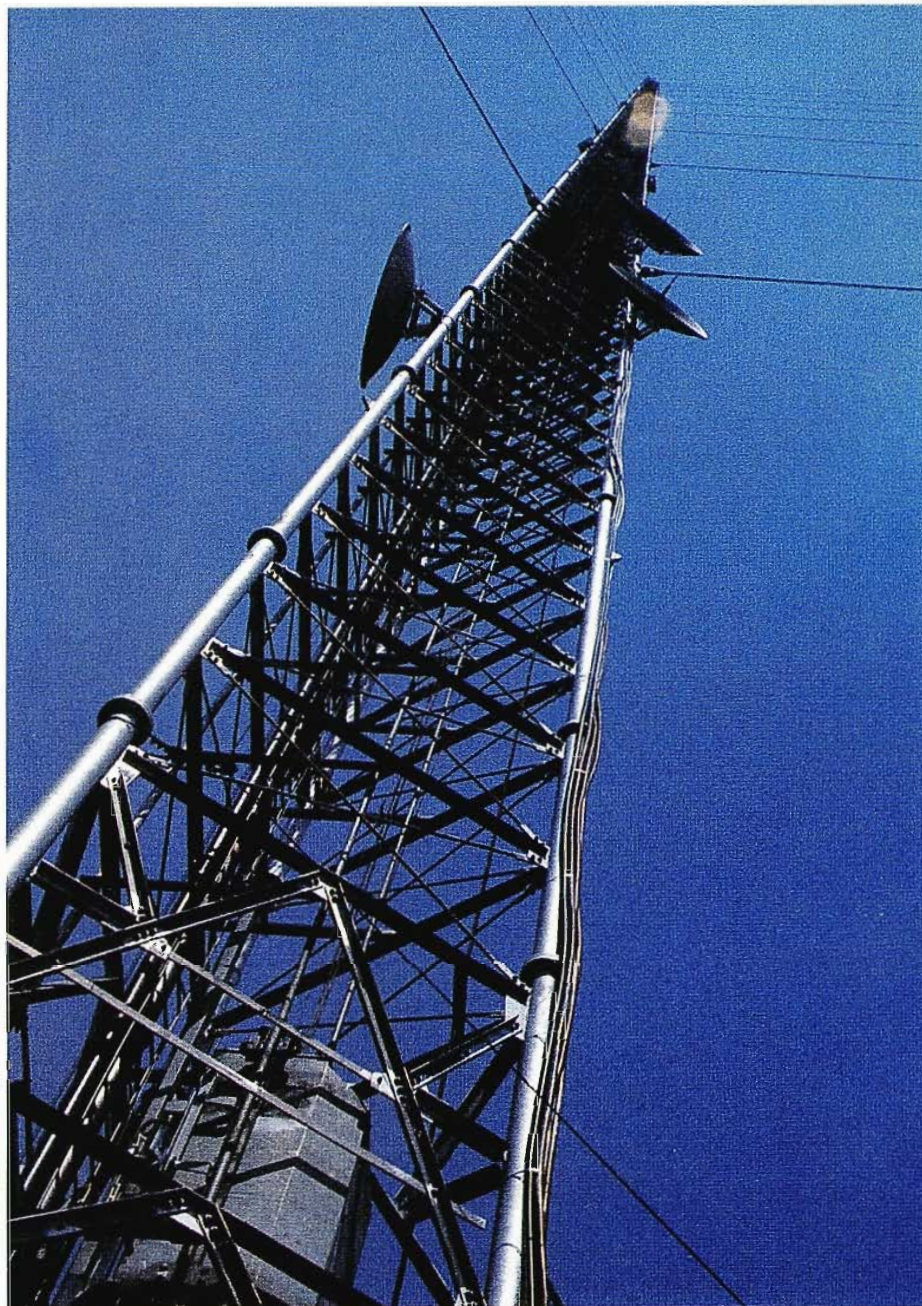

WITN-TV's Tall Tower reaches high, enabling TV-7 to provide better service and coverage for its market area.

WITN-TV is keeping "on top of it all", broadcasting a powerful, circularly polarized signal from its new 2,000 foot tower. Located near Grifton, N. C., in the center of WITN's market area (Greenville-New Bern-Washington), the tall tower is a dramatic symbol of TV-7's on-going program of providing better service to its market.

**\$4 Million Investment**

TV-7's new transmitting system includes the new tower; an RCA TBJ Circularly Polarized Antenna; transmission line; a new transmitter building and a TT-75FH, 75 kW Transmitter. The installation also includes a new RCA FM Transmitter and Antenna.

With its new CP signal and extended reach, the station now covers from beyond Raleigh to the coast, and from Southern Virginia to below Wilmington, North Carolina. The tall tower, antenna, transmitter building and equipment represents an investment of more than \$4 million, which must be considered unusual for a station operation in NSI Market #86.

**"A First Class Transmitting Facility"**

In the case of TV-7, maintaining excellent technical facilities has been standard operating procedure since the station went on-air in 1955. The decision to replace the 20-year old existing General Electric transmitting system was made by W. R. Roberson, Chairman; Dick Paul, President, and Al Manning, Vice President, Engineering.

"We wanted to build a first class transmitting facility," Mr. Roberson remarks, "and decided on the circularly polarized operation because that seems to be the direction that the broadcast industry is moving. We preferred to go with the most technologically advanced equipment currently available rather than to wait for future developments."

**Results Exceed Expectations**

President Dick Paul adds, "Since going on air on October 31, 1979 with the new transmitting system, the results have exceeded our expectations in terms of performance. The decision to invest in the new facility was right, since inflation continues to drive costs upward."

For Al Manning, the project was an arduous one. With the tower, the transmitter building, and the equipment installation all going at the same time, he and his crew put in many long 15-hour days at the tower site.



"KEEPING  
ON TOP  
OF IT ALL"  
IS MORE THAN  
A SLOGAN  
FOR WITN-TV

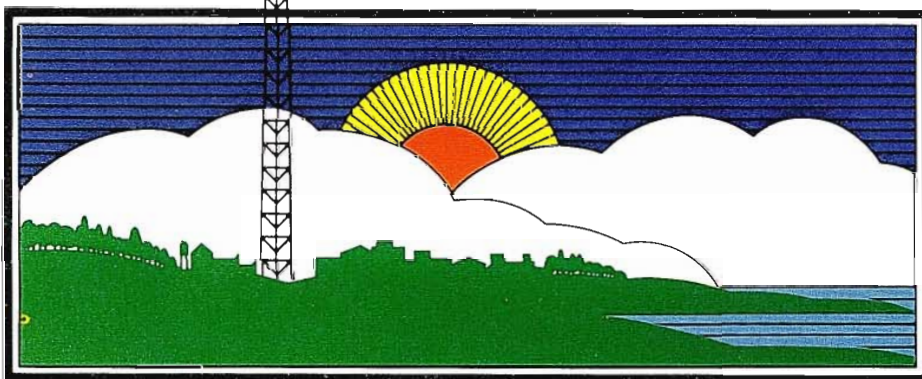

**NORTH CAROLINA**

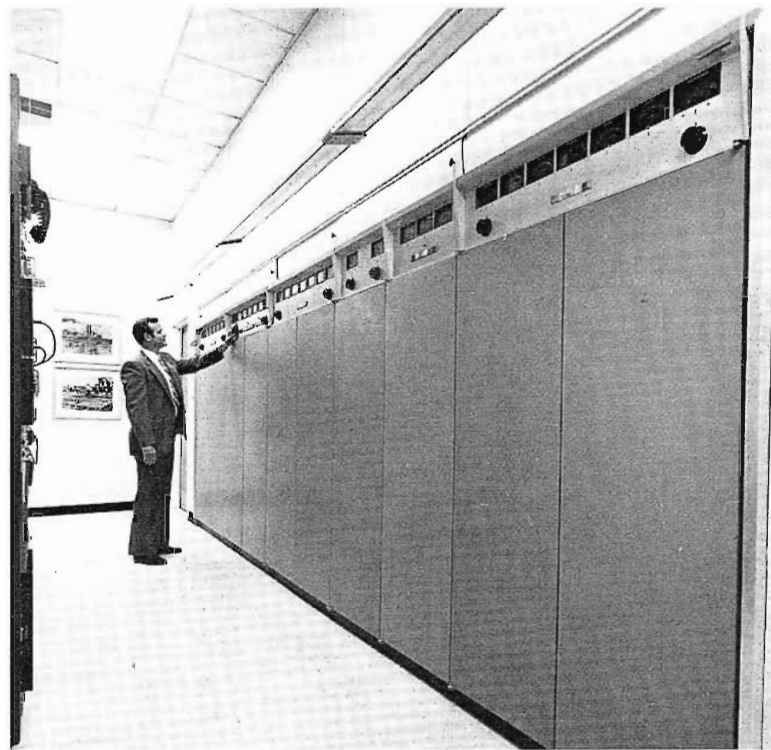
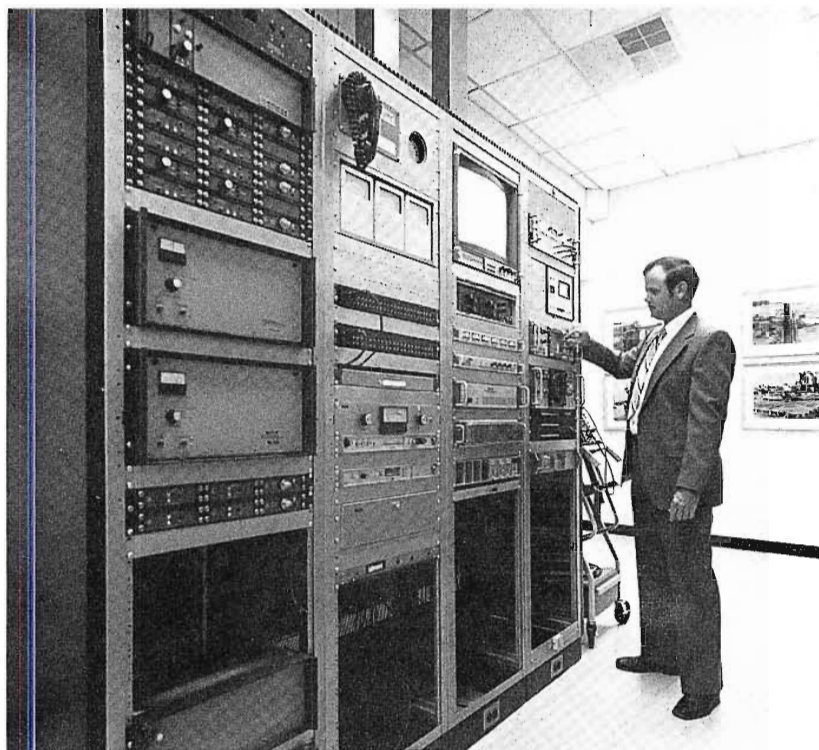

In the Transmitter Operation/Control Room, Al Manning, Vice President, Engineering, checks the transmitter monitoring facilities (left) and the TT-75FH, 75 kW Transmitter (right).

### Planning Communications Facilities For Tall Tower

Planning and management support are the keys to success in completing a project of this magnitude, Mr. Manning emphatically notes. Much of the planning involved determining what communication facilities would go on the tall tower. The tower itself was designed to be sturdy enough to withstand hurricane-belt winds and to accommodate two television antennas as well as two FM antennas at the top plus numerous additional communications equipment at various levels on the tower. (When the tower was completed, WITN-TV sold half interest in the structure to Park Broadcasting, Inc.) One FM antenna is already in place on the tower—WITN-FM's Type BFJ panel antenna. A second FM antenna as well as another circularly polarized TV antenna are scheduled to be installed in the near future. (Also installed on the tower are

some eight microwave dishes as well as additional two-way radio facilities, with ample capacity for more.)

### First TBJ Circularly Polarized Antenna On Air

At the top of the tower is the TBJ 13A7R Circularly Polarized Antenna. Designed and constructed by RCA, the TBJ is made up of 13 panels on each of the three tower facings, a total of 39 panels. TV-7's antenna, as specified by Mr. Manning, is designed for use as a primary and as a standby system. It has a split feed to upper and lower sections so that if one section fails, it will not take the station off the air. Later the transmission line from the old tower will be dismantled and reinstalled on the new tower to provide additional redundancy.

The new FM antenna is a BFJ panel type, which provides better coverage with improved circularity and no holes, Mr. Manning says. The BTF-40 trans-

mitting system has provided trouble-free operation, and the station is happy with results achieved with the new system.

The WITN installation is the first on-air use of the TBJ antenna. Mr. Manning noted that this is a lower gain antenna, which provided the advantages of a better signal to all parts of the coverage area.

### Improved Reception; Extended Coverage

The purpose of the new tower, Mr. Paul states, was to "improve reception in our service area and to reach out further." This goal was fully accomplished: the coverage area was extended some eight miles because of the higher tower height, and in addition, the signal penetration and saturation was increased substantially, particularly to the north and east, providing a better signal to the coastal areas.

The Arbitron survey made in February 1980 shows a dramatic improvement over the one done in February 1979. The difference is a whopping 43% increase in prime time television households over the same period the previous year.

Mr. Paul also pointed out, with obvious pride, that WITN-TV, an NBC affiliate, has 8 of the top 10 primetime shows in the market, based on the Arbitron survey referred to above.



Dick Paul, President; Al Manning, Vice President, Engineering, and W. R. Roberson, Chairman, shared responsibility for building WITN-TV's tall tower and new transmitting facility.

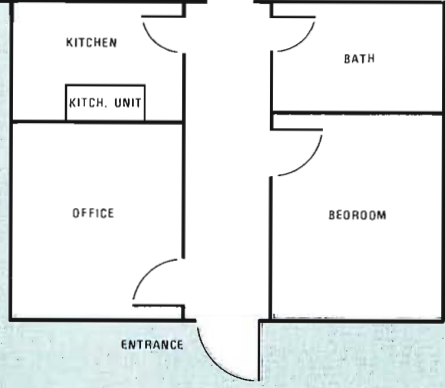
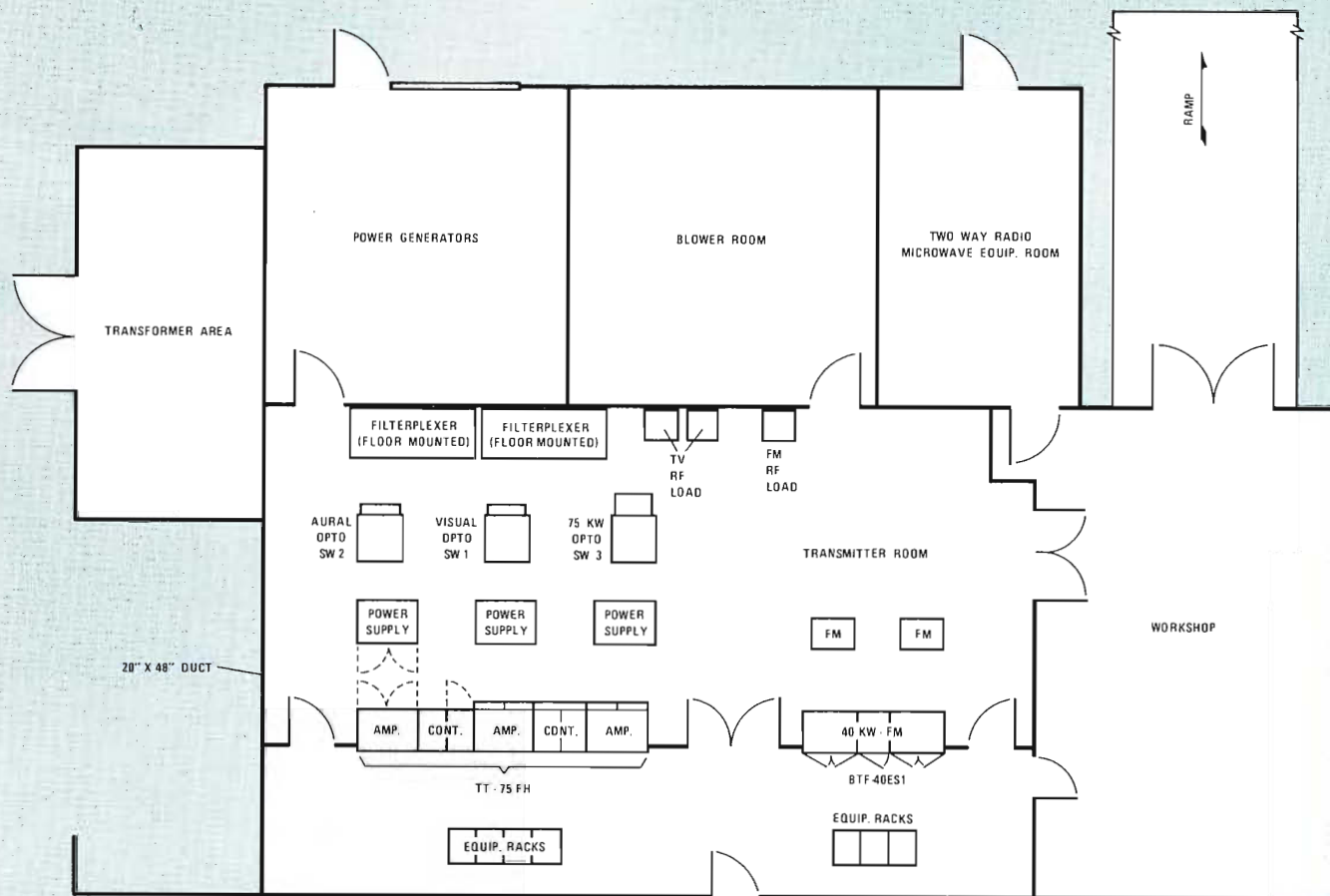

**WITN-TV TRANSMITTER BUILDING**  
(Floor Plan)



WITN-TV Transmitter Building

**Pre-Stressed Concrete Transmitter Building**

The new WITN-TV transmitter building was designed by Edwards Associates, Architects and Planners, with the layout planned and coordinated by Mr. Manning, who started with TV-7 as a transmitter operating engineer before moving to the studio and progressing into management. The building is solidly constructed of pre-stressed concrete walls, with pre-stressed concrete also used for the roof. On top of the pre-stressed concrete roof is a four-inch concrete slab, then a tar and stone roofing which is covered with four-inch by six-inch timbers to protect the building from falling ice.

The building itself is large and includes

facilities for the comfort and convenience of the people working there. For example, there is an office, a lounge/bedroom and complete bathroom and kitchen facilities.

**Operation/Control Area For TV And FM Transmitters**

The transmitter operating/control room is a generous-sized area with the TT-75FH, 75 kW television transmitter on the left and the BTF-40 40 KW FM transmitter on the right. The front line transmitter cabinets are enclosed so only the meter panels are in the control area. Opposite the front line cabinets are racks housing the monitoring, test and telemetry equipment for the TV and the FM transmitters. Cable runs are from the top of the racks, and the racks themselves are free-standing, accessible from front and rear for maintenance. The FM transmitting system status is shown on a visual display, and the system is set up for automatic switch-over.

The rear transmitter cabinets, power supplies, opto-switchers and inside transmission line are all housed in a separate space with eighteen foot ceilings.

**Entire Equipment Installation By TV-7 Staff**

In commenting on the overall transmission system, Al Manning noted that it was a straightforward installation, and with careful planning, 95% of everything went into place as planned. Mr. Manning, his Transmitter Supervisor, Tyson Houston, and one technician handled the entire equipment installation, including fitting, cutting and connecting transmission line and installing the transmitter systems. The TV and FM lines were installed at the same time.

The transmission line, for example, was layed out for best VSWR. It was cut, fit and installed in just eight working days.

The transmitters arrived on site the last week in August 1979, while the Opto-Switchers were delivered on October 3.

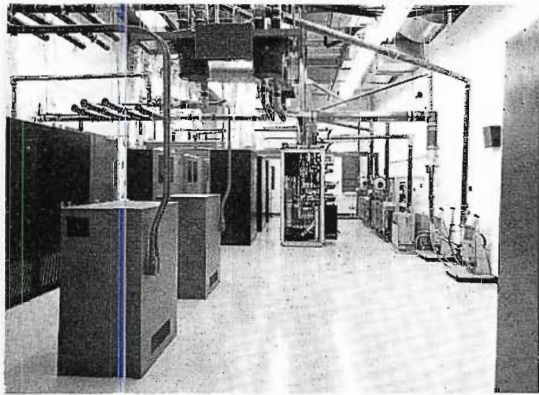

Rear view of TV-7 Transmitter Room, showing spacious layout. Power supplies for BTF-40ES1, 40 kW FM Transmitter are in foreground, with TT-75FH rear cabinets, Opto-Switchers and filterplexers in background.

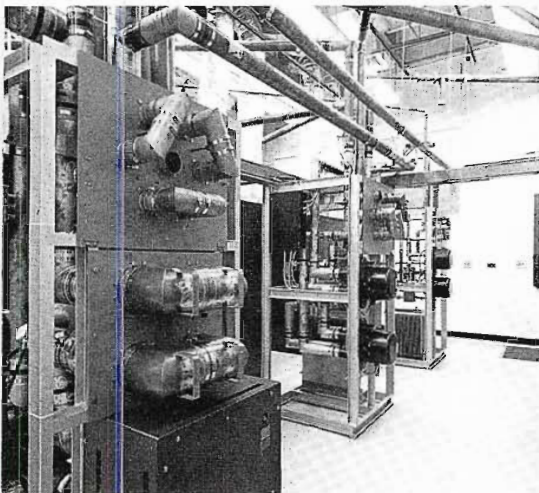

Opto-Switchers and transmission line for TV-7's 75 kW Transmitter.

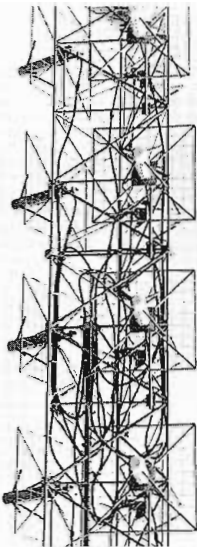

WITN's Circularly Polarized TBJ Panel Antenna stands tall (left) after its long truck ride from RCA's Gibbsboro, NJ antenna facility. (Below).

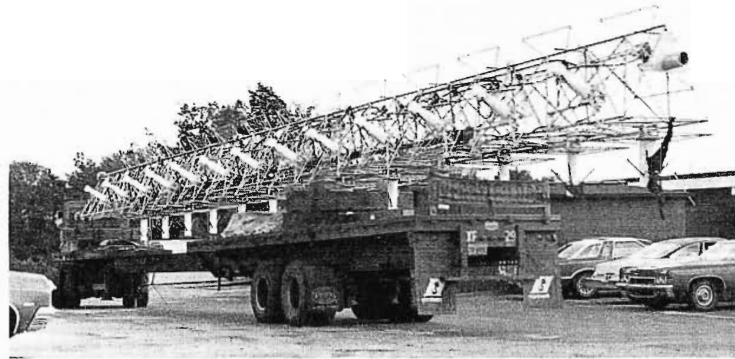

After completion of the installation, the RF system was checked out and it was determined that optimization was not needed.

#### 75 kW Parallel Transmitter System

The 75 kW transmitter system is comprised of three 25 kW transmitters in parallel, with combiners and Opto-Switchers which permit switching any combination of the "A", "B" and "C" transmitters. The system, Mr. Manning says, has worked out extremely well. For delivering the station's maximum 316 kW in circularly polarized operation, 62 kW of transmitter power is required. All three transmitters are on the air at the same time, operating conservatively, with ample power to spare.

#### Positive Pressure Air System

The air system for the new transmitter building has some unusual features. All outside air is filtered through a system which removes particles as fine as cigarette smoke. It is a positive pressure system, with fresh air being drawn in from the outside, through the filtering system, and then through a plenum to ducts under the transmitters. Each 25 kW transmitter, including the power supply, has its own ducts.

During cold weather, provision is made for recirculating warm air to heat the building. When the temperature outside is above 65°, fresh outside air is used; when outside temperatures are below

65°, the warm inside air is recirculated. The front office/operating area is on a separate air conditioning system, so that when the station has completed its planned shift to remote control and the facility is unattended, there will be no need to air condition this space.

A large work area is provided on one side of the building. Double doors of solid steel at the rear of this space open on a ramp which permits driving vehicles into the work area. Another large room at the rear of the building has a separate outside entrance and is reserved for the owners of communications facilities on the tower, who use it for their two-way radio equipment and inside maintenance.

Back-up power for the transmitting plant is provided by a 500 kW Caterpillar diesel generator.

#### Heavy Tower Designed For Hurricane Belt Service

The WITN tall tower was designed and constructed by Kline Iron and Steel, who claims that it is the heaviest 2,000 foot broadcast tower ever built.

Before erecting the tower itself, a major construction project had to be completed. This involved driving more than 500 pilings into the sandy, water-saturated soil, followed by a network of reinforcing steel and hundreds of tons of concrete. The extensive preparation was necessary because of the weight of the tower and its hurricane-belt location.

The new tower has nine anchors, three for each side, with the outer anchors extending 1500 feet from the base. Nine guy wires are provided for each leg.

The time frame for completing the tower and transmitting plant was unusually

short. However, because of careful planning, construction and equipment installation problems were minimal. Mr. Roberson noted that contracts were awarded in December 1978, little more than ten months prior to the October inaugural for the new broadcast service.

After months of preparation, the tower base, with its 8 $\frac{3}{8}$ -inch solid steel legs, was set in place on July 1, 1979. The TBJ circularly polarized antenna was lifted into place atop the tower on October 25, less than a week before the established air date.

Finally, the last and tallest piece of the tall tower—the aircraft beacon for the top—was installed at 3 P.M. on October 31, a mere three hours before air time for the new system.

#### What Does Tall Tower Do?

In promoting its new CP broadcast operation WITN-TV made use of all media—television, radio and print—to advise its viewers of TV-7's extended reach and its brighter, clearer picture.

In its promotion, TV-7 explains to its audience that the tall tower "broadcasts a television signal over 100 miles in all directions:

- reaching over two million people, in nearly one million homes
- in an area of about 28,150 square miles
- a better than 20% increase in the station's service"

#### Keeping On Top

In September, WITN-TV will be celebrating its 25th anniversary of broadcasting, without resting on any laurels. With the transmission system completed, attention is being directed to upgrading studio operations. Additions have already been made, with two TK-46 cameras and two TK-28 telecine systems in place, with further equipment acquisitions in the planning stage.

For TV-7, "keeping on top of it all" is more than a passing slogan . . . and they are "proud as a peacock". □

Urban Renewal in Action:

## NEW WHEC-TV Beautifies Downtown Rochester

After nineteen years of operation from its old downtown facility, WHEC-TV made the big move to a sparkling new broadcast center in downtown Rochester—right next door to its old building. The sign-on for TV-10 at the new location came on June 10, 1979.

Another significant event took place just prior to the move: station ownership changed from the Gannett Company to Broadcast Enterprises National, Inc. (BENI), headed by attorney Ragan Henry of Philadelphia.

For Howard (Skip) Huff, Technical Operations Director, the changeover marked culmination of nearly ten years of planning and waiting. The long time span resulted from WHEC's involvement in a Rochester inner city Urban Renewal plan. Its old multi-story building was a part of a blighted area targeted for leveling and re-building.

Being able to stay in downtown Rochester suited Jack Decker, President and General Manager of WHEC-TV just fine. "We chose this location to reflect our confidence in the future of a revitalized downtown. Rochester is our city of license, and we should be in it."

### Design Innovations

Unsurprisingly, the new TV-10 build-

ing was carefully planned for its function as a modern television broadcast center, with special attention given to efficient layout and workflow.

Beyond these basics, however, there are a number of innovations and design elements which verify the "state-of-art" status of WHEC's new facility. In today's energy-conscious environment, perhaps the most unusual feature of the building is its closed loop heat pump system for heating and cooling. "We may never have to heat this building," remarks Mr. Huff.

Designing the new building was primarily a matter of knowing what was wrong with the old building, Skip Huff oversimplifies. "For example, our old control room was only 900 sq. ft.; the new one is 1400 sq. ft. The old News Room was really three different rooms located two floors above the studio—which made for some hectic charges up and down the stairs before and during the newscasts.

Planning for the new building started in 1976. We had known for ten years that a move would have to be made, but the timing was not precise. One year was spent in planning, layouts and detail after the architect was named. The build-

The lobby of TV-10 is striking—dominated by a 270 degree cantilevered helical stairway to the second floor offices which is supported by reinforced concrete in the basement and counter-balanced on the second floor.



ROCHESTER



ing went out for bid in December 1977 and took about a year to build. Ground was broken in February 1978, and our engineering installation crew was the first to move in starting in January 1979, preparing the technical area."

The TV-10 building is a modern, 25,000 sq. ft. two-story structure, with an exterior of warm-toned brick on the first level, and precast off-white concrete on the second level, with generous expanses of tinted thermal pane glass lining the perimeter offices. All functions which have to do with getting the picture on-air are located on the first floor, while the administrative offices are on the second level.

Occupying the front of the building on the first floor is the News Department. The space allotted to the news operation reflects WHEC's dominant #1 position in news in the Rochester market.

The studios and technical areas are at the rear of the building, accessible from a parking lot entrance or through the lobby.

#### Heat Pump System

Mechanical construction detail for the new TV-10 building includes some unique "wrinkles", probably the most intriguing of which is the heating and

cooling system. This is a closed loop heat pump system which was specified by Skip Huff in response to the need for energy conservation.

This innovative heat recovery system provides for recycling the heat generated by the studio lights and TV equipment. There is no central heating system in the building, Mr. Huff notes. All interior areas are maintained in the air conditioning mode at all times, and each outer perimeter office or area has either one, two, or three heat pumps built-in, depending on the space.

The system carries heated water to heat pumps in winter, and carries heat away in summer. A 10,000 gallon water tank in the basement stores heated water. In the summer, heat from the water is passed through evaporative coolers and is exhausted into the air because it is excess heat.

There is a second backup system—Megatherm—which has a 750 gallon sealed tank with super-heated water. There are two heat exchangers for the Megatherm system: one for hot water requirements in the building, and one for pumping water into the heat pump loop in case there is not enough heat generated in the building.

This innovative heat recovery system was designed by Baumer and Knowles, a Rochester mechanical consulting engineering firm.

#### Mechanical Systems Located Inside Building

There are three air handling systems in the building: one for the studio; one for the rest of the building, and one for fresh air intake. To enhance the exterior appearance, all mechanical systems are housed within the building itself. Only the microwave tower, a functional necessity, projects above the roof:

Basement space is under two-thirds of the building, and is used for housing air conditioning equipment; water storage tanks for the heat recovery system; telephone mainframes, power inputs, and additional storage area. The master ground panel for the technical equipment is also located in the basement. The ground is a 12-inch copper strip, 80-feet long, which lays on bedrock, immersed by water and covered by sand.

#### Planning the Technical Area

About a year of serious planning was involved in developing the layouts for the Studio, Master Control and Technical areas, according to Chief Engineer

"Television is a visual medium," comments Skip Huff, Director of Technical Operations. "Therefore we felt that we had to be visual as a building. That's why the exterior is distinctive and attractive. Next, the area which all visitors to the station see is the lobby, so it had to be the most impressive part of the building."

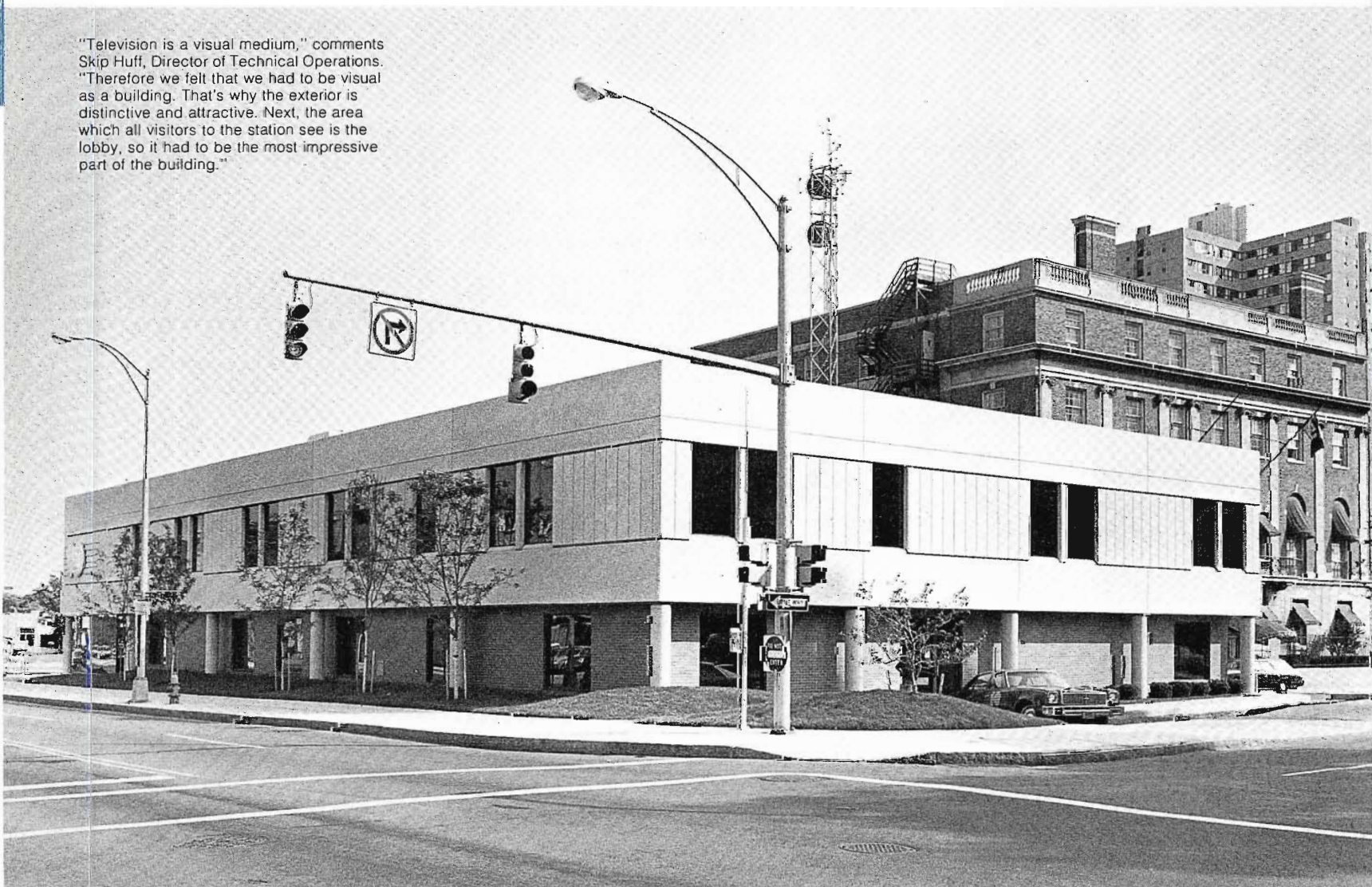

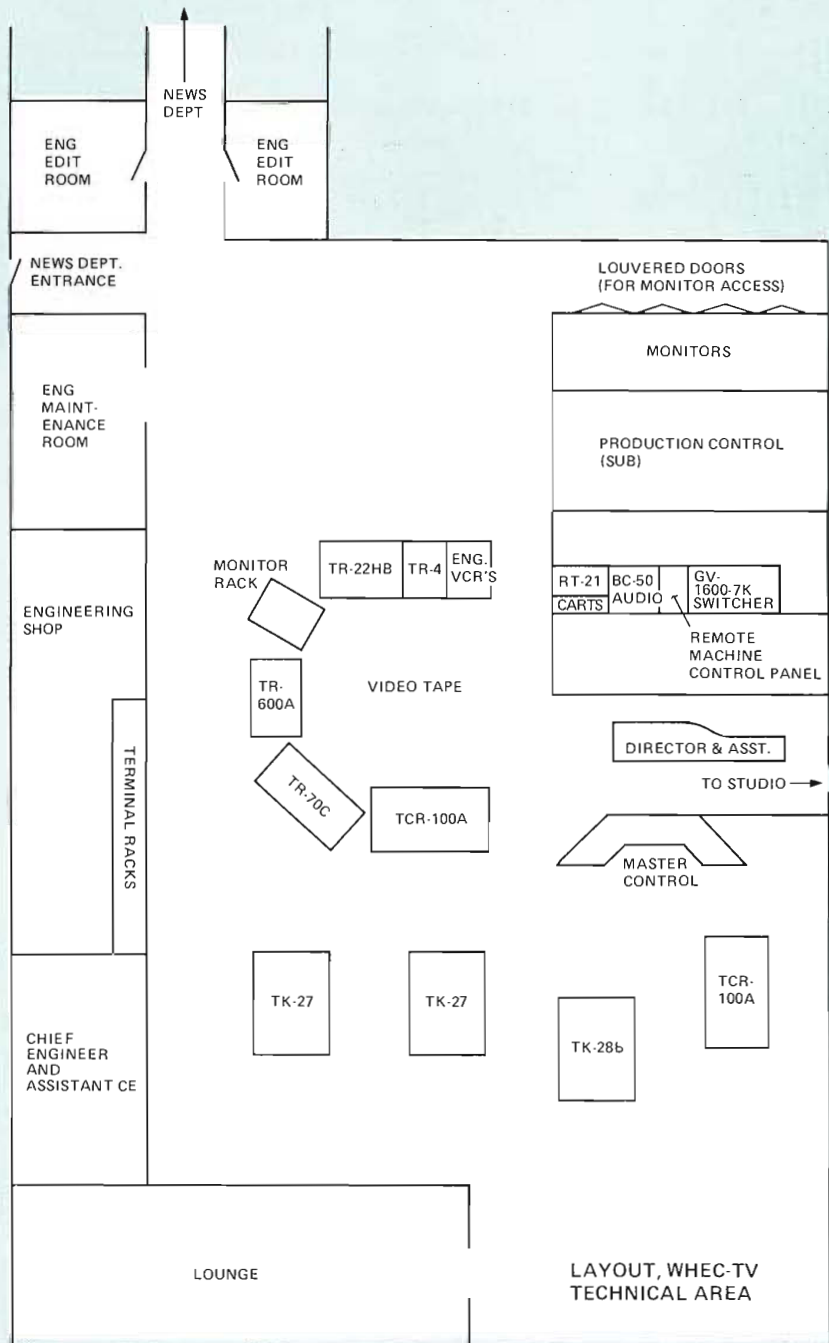

Jerry Evans. The inefficiencies of the old layout provided a solid basis for planning the new facility so that the traffic flow would be as convenient as possible. Visits were made to other stations to check out ideas. In most cases, however, checking out other facilities provided useful guidance on pitfalls to avoid. "The final result was pretty much as planned," Mr. Evans says, "and it is a pleasure to work with everything on one floor." In the old location, the technical operations including the control room were all housed in cramped quarters in the basement.

#### Operational Convenience

A "walk-through" of the technical area at TV-10 immediately reveals its operational convenience. Master Control is centrally located, and set up so that it can be a one-man operation. Behind the Master Control console is a TCR-100A "cart" machine and a TK-28 film island which are used for on-air operations. The MC operator usually handles loading the tape and film machines. There is a projectionist/VTR operator on hand until after the 11 P.M. news. One man runs the station from then until sign-off.

In front of the MC console is a window which looks in on the Production Control room. This gives the MC operator a view of all available sources for convenience in previewing and switching, especially during newscasts.

#### Production Control

The Production Control Room has two doorways—one to the Studio, and one to the VTR/Technical area. The space is set up on two levels, with the Director elevated above and behind the audio and video control positions. This arrangement permits excellent visibility and allows a "flow-through" of traffic to and from the studio and technical areas without disrupting the Production Control operators who are located on a lower level.

#### Video Tape Complement

The accessibility of the video tape area also enhances production efficiency. The tape machines are arranged in a horseshoe configuration, which makes it convenient for one person to operate these as needed for production use—dubbing; editing, etc. The open end of the horseshoe looks in on Production Control, providing close contact with production operations.

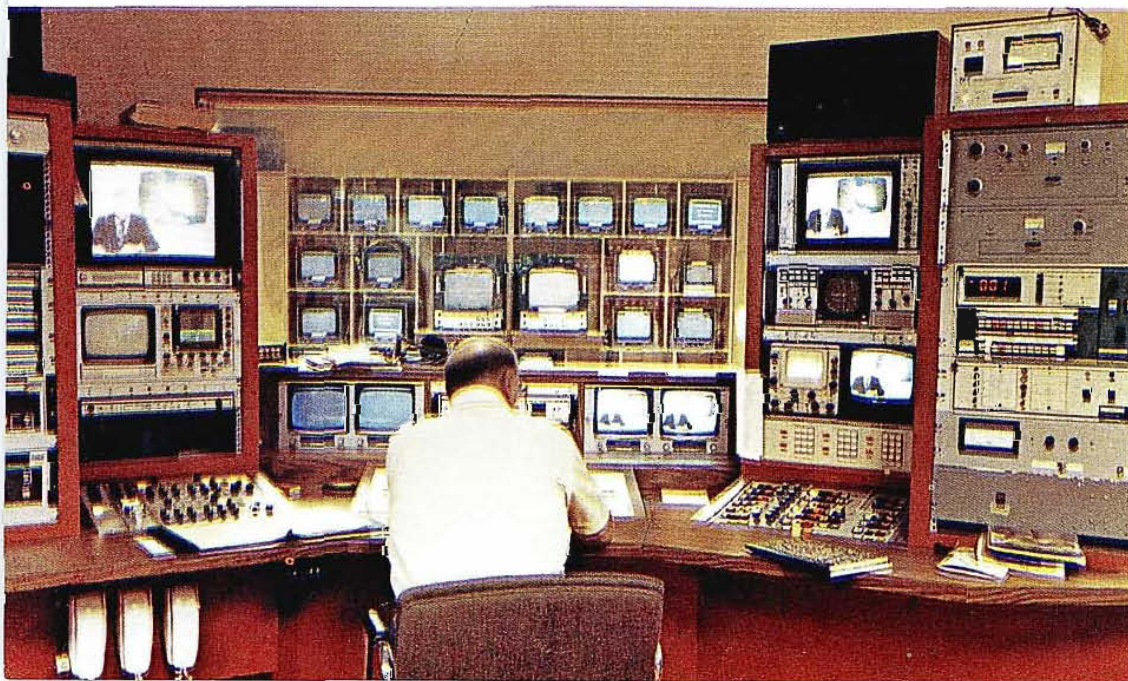

A window in front of the Master Control operator looks in on Production Control with its banks of video source monitors.



Production Control is on two levels, with audio and video switching and remote machine controls at the lower level.



Another view of MC. The TCR-100A at right is used for airing commercials.

The complement of VTR's includes four generations of RCA quad tape machines:

**TR-600A.** Used primarily for production. The built-in editor permits single-frame edits and has been a useful feature.

**TR-70.** Shares electronics with the TCR-100. Used for dubbing tape material to "carts".

**TCR-100** WHEC operates two TCR-100's—one located at Master Control and one in the tape production area.

**TR-4.** Used mostly by the News Dept. for recording CBS news feeds and for dubbing cassette recordings to quad when assembling news programs.

**TR-22B.** Program playback machine.

A bank of cassette VTR's located close to Production Control and the ENG editing area is used for airing ENG tapes.

#### Two TCR-100's In Use

WHEC makes effective use of the two TCR-100's. The new machine is located by Master Control and is used for on-air playbacks. Most of the time the MC operator loads the machine, usually for one break ahead during network programming, and further ahead for local programs. An average of 300 carts are aired daily, according to Mr. Evans. At present, only tape spots are dubbed to "cart", and a spot reel is made up for the film spots.

Since the new TCR-100A was already installed and in operation at the new facility, it was not necessary to make up a tape reel during the changeover.

The TCR-100 is sometimes used as a third camera at TV-10 for production. A work tape of "carts" is prepared from pre-recorded material for use as inserts during editing sessions. Sometimes news stories are loaded on one "cart" machine and commercials on the other. This is a convenient way of assembling the weekend news, using pre-recorded material dubbed to "carts", for

smooth, easy switching from story-to-story.

Production is handled between 2:30 P.M. and 11 P.M., with breakaways for the evening and late news.

#### Layout Provides Full Accessibility

In addition to the TK-28 film island near Master Control, two TK-27 telecine systems from the old building are installed in the technical area. The TK-28B is used for airing syndicated programs, but increasingly is in demand for production because of its automatic color correction features.

Computer' flooring is used for the Technical Area, permitting easy installation and rearrangement of the equipment at any time. The wiring is accessible, and the equipment is positioned away from walls for convenience in operation and in maintenance.

Another example of functional equipment placement in the Technical Area is the use of terminal racks to form a wall of the shop area.



The Video Tape area at WHEC-TV features a horseshoe arrangement for operational convenience.





Film islands and other equipment are on computer flooring, with access from all sides.

stored. Included were:

- TCR-100A
- TR-600A
- TK-28 Island
- BC-50 Audio Console
- 1600-7K Production Switcher
- 1600-4S Master Control Switcher
- GV-400 Routing Switcher.

In addition, a large array of monitoring and test equipment; distribution amplifiers; patch panels and other terminal equipment were ordered. The advance purchase and installation of this equipment enabled the station to make the facility changeover overnight.

Setting up the new technical facility was handled entirely by the WHEC technical staff. A four-man crew moved into the new building late in January 1979, when it was still under construction to install system wiring and equipment. The team included Jerry Evans, C.E.; Bob Erskine, Assistant C.E., and technicians John Murphy and Ted Brew.

Bob Erskine notes "We knew about where each piece of equipment would go, but had flexibility for making adjustments as needed. Before installation, we put white tape on the floor to locate the equipment and wiring runs. Parts and machines were then placed in their prescribed locations. The computer flooring simplified the wiring job."

"System timing was worked out on paper," Mr. Evans adds, "and worked out quite well. We had to make a few minor adjustments, but basically everything came out pretty close."

#### Remote Machine Control Panels

The TV-10 technical staff designed its

own remote machine control panels which are duplicated at Master Control and in Production Control, and can be delegated to either position. Remote machine controls are provided for all quad VTR's; all ENG VTR's, and all film projectors. The remote control setup provides "roll" capability in Production Control as well as at MC. The TV-10 system used 5-second rolls on VTR's.

#### Patchable Connector Panels for ENG Cameras

Another innovation by the TV-10 staff is a patchable camera connector panel for use with ENG cameras. These connector panels are located in the studio; on the roof; in the News Room, and outside the building at street level. The video outputs from the panels come up as inputs on the Production Control switcher. The interface panels provide full audio and video facilities, permitting the ENG cameras to be used in the Studio as well as at the other locations. The audio comes in as additional mic inputs for the BC-50 audio board in Production Control.

#### Studio Construction Provides Total Sound Isolation

The studio is 40' x 60', and includes a permanent news set and a set for the "Ed Meath" program which is aired live each weekday morning.

The studio lighting design was handled by Imero Fiorentino Associates. Double curtain tracks surround the studio, with provisions for switching the 90-foot cyc curtains from one track to the other. There is also a "parking" track for holding the curtain not in use. The

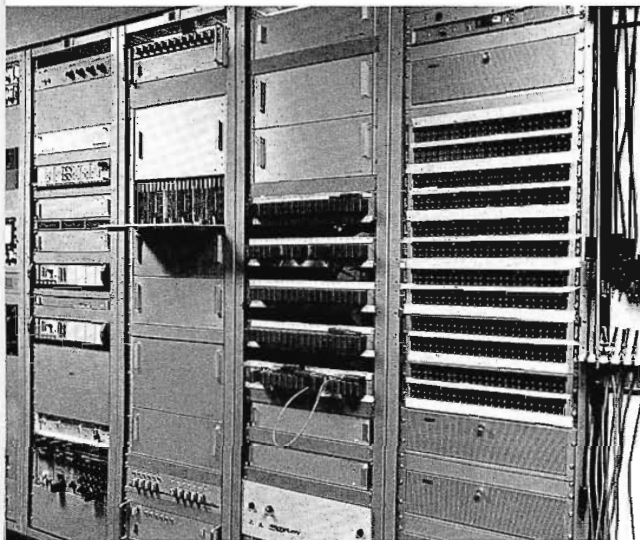

On one end of the Technical Area, terminal racks are used to form a wall of the engineering shop.

The Technical Area and the adjoining Tape/Film Storage Room are on a separate environmental system which is temperature and humidity controlled. In the Technical Area, the air enters under the computer flooring, flows through the equipment, and exhausts at the top.

#### Improved Headwheel Life; Less Downtime

One of the problems at the old facility was that of dust and dirt penetrating the equipment, resulting in failures and short headwheel life. The tape and film equipment moved to the new facility was thoroughly cleaned and checked out first. Since moving, headwheel life has increased substantially, and there has been a reduction in downtime for maintenance. A part of the improvement can be attributed to a rule that no smoking or food is permitted in the control room area. An attractive lounge is provided in the technical area for smoking and snacking.

#### Advance Equipment Purchases Permit Smooth Changeover

In preparation for the move to the new building, a number of new equipment items were ordered in advance and

Remote machine control panels were custom-designed by the TV-10 technical staff.

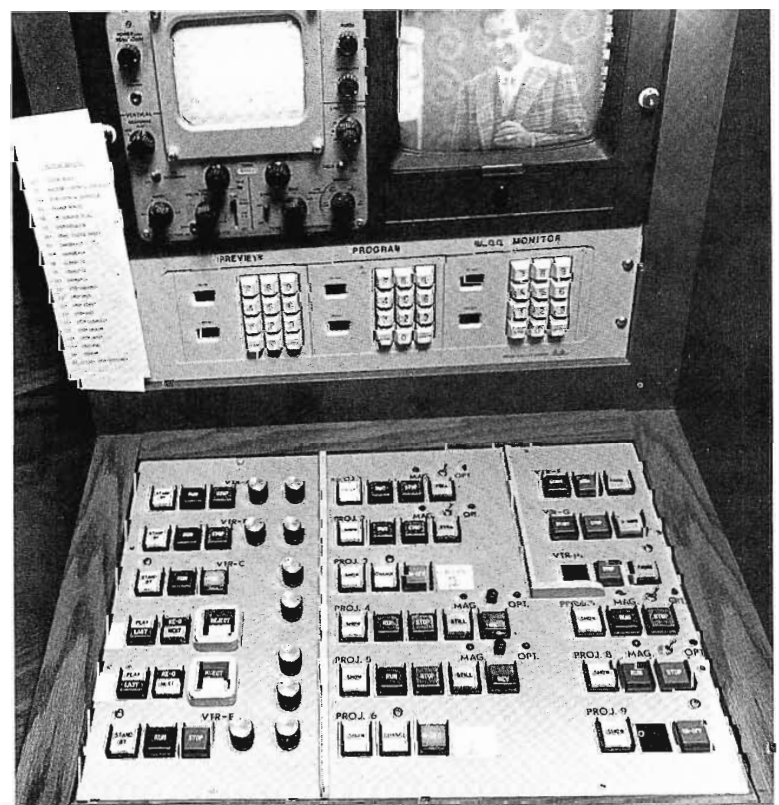



The ENG editing suites are located adjacent to the Technical Area for convenience in delivering edited tapes for broadcast.

lighting system includes a new patch-panel lighting control system, dimmer bank and control console. The console can be rolled from the studio into the adjoining Production Control room and operated from there if desired.

The studio was constructed as a "building within a building" to isolate it from external sounds and vibrations. Studio walls are sand-filled 12-inch concrete blocks. The 8-inch concrete floor is supported by caissons set in bedrock. Steel beams which frame into the studio walls are set on Neoprene pads to assure isolation from the rest of the building. The ceiling contains over 12-inches of concrete and styrofoam insulation. O. L. Angevine and Associates of Buffalo were the acoustical consultants for the project.

A high volume, low velocity air handling system is used for the studio for minimum noise. The ductwork is lined and further isolated by the use of flexible joints. Silencers and resilient hangers are also employed to eliminate the transmission of mechanical noise through the system.

Studio cameras are hard-working TK-45's which were moved in from the old building. According to Bob Erskine, Assistant C.E., the cameras were in operation within a half-hour. "We put the cables in ahead of time, using the same cables we had from our earlier TK-42 cameras, and the timing came out right. We put power to the cameras, and they worked, with no problems."

#### 100% ENG Operation

"TV-10 is Number One in news in the market," remarks Mr. Huff, "and we are moving to strengthen that position by expanding our local evening news to a full hour." (This has now been accomplished)

The ENG news operation at TV-10 includes six cameras with two-man teams—a reporter and a cameraman.

Five cars and a microwave-equipped

van are used for ENG coverage. The microwave van is equipped with a switcher, permitting its use in handling remotes with as many as five cameras. This arrangement is particularly useful for such events as election night coverage. The rack equipment in the van is on casters and can be rolled to the required location, with only audio and video lines going back to the van.

"We have been 100% on ENG since July 1977, and have not used film for news since then," adds Mr. Huff. "The ENG investment was more than a quarter million dollars, but it is paying off in eliminating film and chemical purchases which had been running about \$85,000 per year."

For the News/ENG operation, there is a separate side parking area and reserved entrance next to the News Department and technical area. Inside this doorway, the ENG equipment is stored in the Technical Area, where one technician is assigned to handle maintenance. There is also an entrance into the News Department, with the ENG Tape Edit bays located closest to the Control Room. This arrangement provides for a smooth flow of material.

An RCA 450 two-way radio system is used for communicating with the microwave van and setting up the most desirable signal path. The receiving control point is located in the Technical Area

near the ENG VTR's. The News Room also has a mic for communicating with reporters working with the microwave unit.

#### Moving In—And Moving Ahead

The move to the new building was accomplished in stages, starting with the small technical crew in January 1979. In May, the other operating units began re-locating. The complete on-air changeover was made on June 10, 1979 at 7 A.M. The switch was made so smoothly that viewers were not aware of the change.

With the change in ownership, effective June 7, 1979, WHEC-TV is distinguished as the first black owned network-affiliated VHF station in the country. TV-10 carries a full block of CBS network programming.

Looking ahead, Jack Decker anticipates an increase in local programming in the new decade.

"TV is becoming increasingly aware of its responsibility to the entire community in terms of the kinds of programs and news we report," he said. "We are analyzing, for example, how our news operations fit into the total scope of available news sources. We're handling more tough subjects, and we plan to continue responsible analyses of important issues like child abuse, nursing home problems, drugs, and so on."

"We have strong commitments about being a part of the community and being involved. We are not just here as a money machine to put on entertainment programs."

"The investment in this new building and its equipment complement confirms our conviction that television is a changing expanding medium. In planning for this new building, we had to keep in mind not only what is today . . . but also what may be tomorrow." □

Colorful "supergraphics" cover whole walls within the building. Themes for the wall graphics on the second floor include variations of the station logo and a stylized Rochester skyline, all fashioned from varying shades of carpet fabric.

The objective was to create an environment that would not only meet the requirements of a major TV facility, but also provide a visually exciting place for the people who work there. Seated are Skip Huff, Technical Operations Director, and Jack Decker, President and General Manager.





## HOW TO GET THE BEST PERFORMANCE FROM YOUR RCA TK-76 or TK-760 with SATICON TUBES

The success of the RCA TK-76 and its companion, the studio or production TK-760 camera, has been an industry phenomenon. Reliability, stability and ruggedness of the camera have established a new standard of expectations for broadcast cameras.

Those users who specified Saticon tubes for these cameras have also experienced the improved performance that these tubes produce in ENG, studio and production service. Resolution of 18 mm Saticon equipped cameras exceeds that of the conventional 25 mm lead oxide cameras and approaches that of the 30 mm lead oxide cameras. Less flare into low lights and the consequent ability to



**ROBERT G. NEUHAUSER**

Robert G. Neuhauser was graduated as a Bachelor of Engineering from Drexel University in 1949. Since that time he has been employed by RCA in Camera Tube Development, Manufacturing and Application Engineering. He was responsible for Image Orthicon and vidicon development engineering and application engineering, and was Project Leader of the Vistacon development and manufacturing program at RCA. He is a Senior Member of the Technical Staff, RCA Electro Optics and Devices, RCA Corp., Lancaster, PA. He is a Fellow Member of the Society of Motion Picture Engineers and was the recipient of the David Sarnoff Award for television of that society. He is the author of more than 20 papers on the subject of camera television tube design and application.

handle high contrast scenes without wiping out the foreground or distorting low light colors are the second most important performance features of these stable tubes.

Extremely long life of Saticon tubes, the near absence of blemishes during life and the excellent mechanical and electrical stability of the tubes produce pictures that "hold" and do not require readjustment of registration or tube adjustments for long periods of time. This reduces camera down time and maintenance costs as well as tube replacement costs. As an added bonus, the price of Saticon tubes is less than the price of Plumbicons.

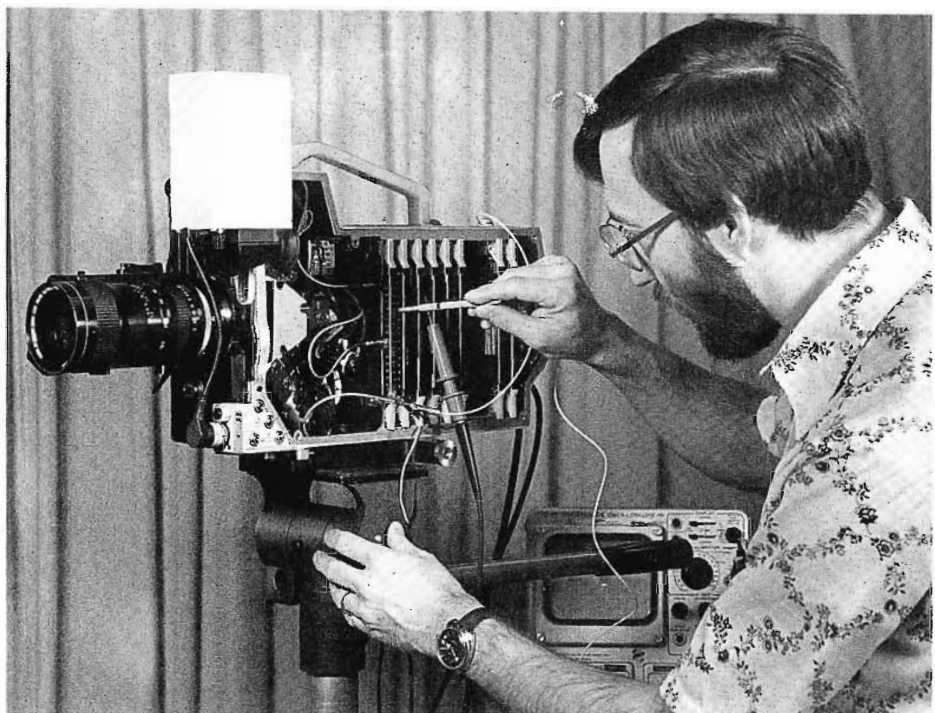

TK-76 Camera Set-up



The BC4390 Saticon is an electrically and pin compatible Saticon tube made available for easily converting the TK-76 and TK-760 cameras to Saticons.

The BC4390 produces the same high quality pictures as its predecessor and in addition has a faceplate extender that prevents dust that may accumulate on the faceplate from being close to the plane of focus.

Proper tube and camera set up adjustments are necessary to achieve optimum performance. Most problems encountered during the introduction phase of the Saticon tube were caused by improper tube adjustment and associated camera set-up problems.

#### Bias Light

Proper bias light setting is important. The Saticon tube responds very rapidly to bias light. Lag is reduced and build-up is speeded up. For proper operation it is necessary to operate with at least 5 nA of bias signal in each channel. High levels of bias light present no problems for the Saticon because of its very uniform photoconductor. Also the faceplate extender of the BC4390 Saticon tube has been designed to avoid shadowing of the bias light source which, if present, would produce non-uniform background.

#### Beam Setting

Beams are set to handle precisely 4 times the normal 100% highlight signal level in each channel. The Saticon tube can handle this value of beam current without deterioration of resolution. With this increased beam current, the after effects and comet-tails of specular highlights are greatly reduced and the camera can handle situations such as shooting against a sunlit wall or a bright sky without blooming. The low flare, of course, preserves the low light colors in the presence of this highlight overload.

#### Flare

Flare adjustments are also important. When Plumbicon tubes are replaced with Saticon tubes, the flare controls must be backed off substantially. If not, the circuitry will respond to high brightness information and push the blacks below zero level and produce weird low signal level effects that appear to be lag or flare.

#### Target Voltage

The target voltage should be set to 50 volts. In some cases a tube may exhibit an image burn on long exposure. If this

should occur, the target voltage can be adjusted a few volts to eliminate this tendency.

Calibration of signal current, bias level current and the beam current setting is made by measuring the signal directly out of the pre-amp coax cable. This can be done most conveniently by connecting this coax directly to an oscilloscope input by a special test cable AJ2236 available from RCA Solid State Division, Electro-Optics and Devices, Lancaster, PA 17604. This cable consists of a miniature made coaxial connector connected to a BNC type connector which is connected directly into an oscilloscope.

#### Installation

Installation of the tubes is straightforward. The BC4390 tubes are supplied as red, blue and green versions. The color selection is solely on the basis of sensitivity for the intended channel to obtain optimum camera sensitivity and balance between the signal currents in the three channels.

Here are the step-by-step procedures necessary when setting up newly installed Saticon tubes in the RCA TK-76 or TK-760 cameras, or when you are checking any Saticon equipped camera for proper operation.

This set-up includes the following adjustment procedures:

- Proper scan size
- Target voltage
- Signal current levels
- Bias light levels
- Beam setting level
- Shading and black level adjustment
- Flare adjustment

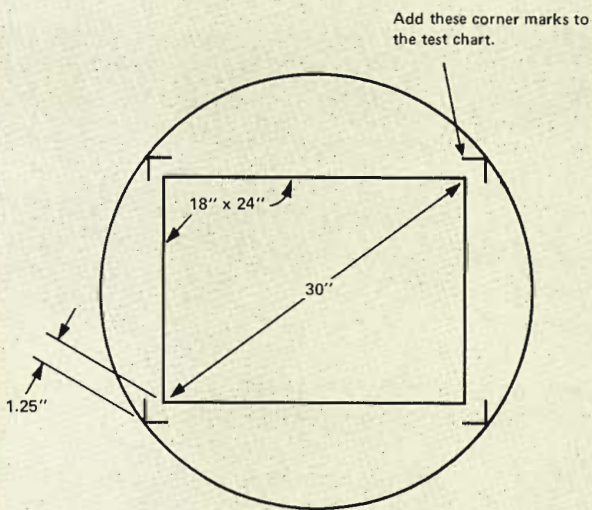

Fig. 1

Visible area when over-scanned. (Use green channel).

Set lens zoom and test pattern distance to achieve this condition. Then turn off overscan switch and adjust to only scan the 18" x 24" test pattern.

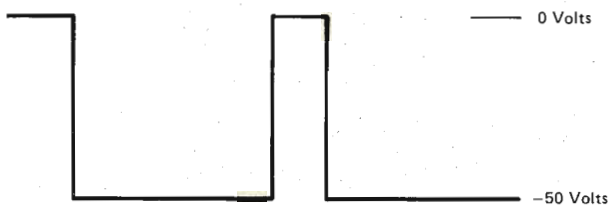

Fig. 2

### Proper Scan Size

The visible "opening" of the Saticon tube is different in diameter from Plumbicon tubes. The following procedure can be used with *any* camera to achieve a properly sized and centered image on any BC4390 Saticon tube. Set the size while viewing the green channel image only. (Fig. 1).

If the overscan resistors of the TK-76A are not changed, use the previously mentioned method of set up. For the TK-76B, TK-760 and TK-76A with the revised overscan resistors, put the Saticon\* scan switch to the Saticon overscan. Position a standard 3 x 4 test chart so that the corners just touch the circular opening as seen in the green channel. Adjust green height and width controls to just scan the full test chart. Then turn off the overscan switch and the camera will automatically scan the proper area. This is the *normal* procedure outlined in all of the instruction manuals.

### Target Voltage

Target voltage is the difference in the voltage between the cathode and the target. The voltage on the actual target connection is 0 (or ground) and the cathode is operated negatively to supply the proper operating target voltage in the TK-76 and TK-760 cameras. The target voltage for Saticon tubes should be 50 volts.

Blanking is also applied to the cathode. The target voltage control should be adjusted so that the voltage during active scan time should be -50 volts. See Fig. 2.

\*TK-76A's have only 1 overscan switch. Use it. See section on TK-76A conversion, page 48.

To adjust, take off the right cover of the camera. On TK-76A cameras, remove the heat sink board from the deflection board and locate the appropriate blanking transistor. Q7 (red), Q107 (green), or Q207 (blue). Put a scope probe on the transistor cover (scratch through the protective coating) and measure the target voltage as shown on Figure 2 while adjusting the target voltage.

On TK-76B and TK-760 cameras, the target voltages are ganged on a single control. It is *not* necessary to remove the heat sink cover on these cameras since Q107 protrudes beyond the heat sink shield at the lower left of the deflection module. Measure the target voltage here while adjusting the target voltage.

### Calibration of the Video Pre-Amplifier for Bias and Signal Current Level

Calibration of the video pre-amplifier signal level is different on the earlier models of the TK-76A. Cameras with serial numbers below 7400 have a feedback resistor of 665 K ohms. All other models have a 1 meg ohm feedback resistor. If in doubt, it is advisable to check and record the value of the resistor on the pre-amplifier (R30) when the deflection coil assembly is removed for tube replacement.

With the 1 meg ohm feedback resistor, the signal out of the pre-amplifier coaxial cable indicates 1 mV of signal for 1 nA of current from the tube. With the 665 K ohm resistor, the signal output is .66 mV for every nA of input current.

### Bias Light Adjustment

The bias light signal level can be measured using the AJ2236 test cable. Plug the test cable into the pre amp coaxial cable connector and *cap the lens*. Use the vertical rate trace on the oscilloscope and adjust the bias light control so that the average signal level above the negative vertical pulse is 6 to 8 mV. (Fig. 3).

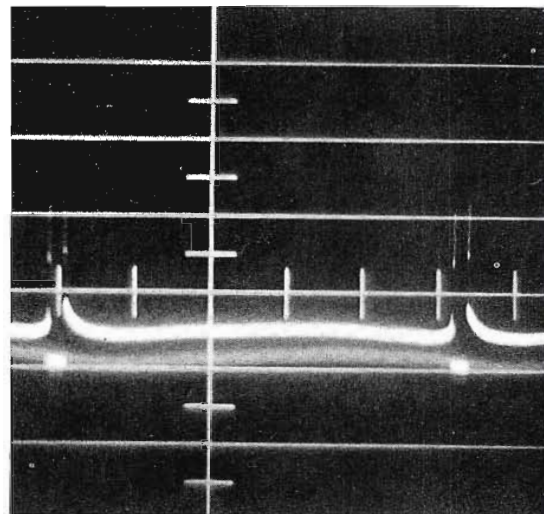

Fig. 3. Signal when measuring bias level. Scope set on 10 mV/cm. Bias level = 5 mV = 5 nA.

Adjust the bias light control to produce at least 5 mV but less than 10 mV signal as shown in Fig. 3. Check all 3 channels and bring the lowest one up to 5 mV. (3.5 mV in TK-76A with the 665K ohm pre-amp feedback resistor.) If the bias level is above 10 mV in any channel, it may not be possible to achieve proper black level set and black balance.

This level of bias will produce nearly equal low lag and fast build-up in all channels, so that any residual lag or build-up will be neutral and not exhibit color changes with motion.



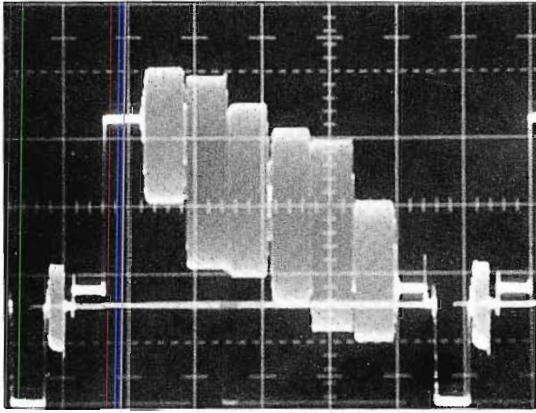

Fig. 4. Color Bar Output Signal (Horizontal Rate).

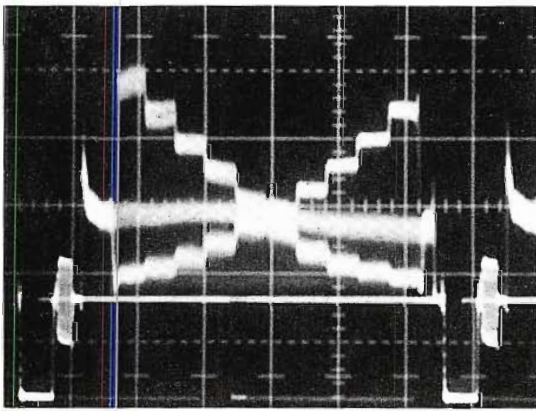

Fig. 5. Camera Video Output (Horizontal Rate).

### Signal Currents

If Saticon tubes were previously set-up in the camera and the set-up is being checked out, it is advisable to check to see the levels of signal current are being utilized.

Remove both sides of the camera. The camera lens iris control *must* be set on the manual position. Focus the camera on a "step" chart and then adjust the lens iris manually to produce an output white highlight signal that matches the 100% signal level of the internal color bar generator. (Switch between bars and picture by using the switch on the side of the camera.) See Fig. 4 and 5.

Next, the pre-amp coax cable that comes from the green camera tube coil assembly should be unplugged from the Input Proc. board. (If the iris control is not on manual, the iris will open as soon as this cable is unplugged, and there goes your calibration of signal level.) See Figure 3.

The test cable #AJ2236 should be plugged into the coax cable and attached directly to the input of the oscilloscope, which is set at the horizontal rate. The peak black-to-white signal level (horizontal retrace level to peak white) should be measured in millivolts. This level will be approximately 225mV, which is equivalent to 225 nA

of signal current. A signal between 200 and 250 mV means the tube and preamp signal levels are correct.\*

\*Note for early TK-76 preamplifiers using the 665 K feedback resistor, the values should be  $\frac{2}{3}$  those quoted. (150 mV instead of 225 mV.)

If a camera is being equipped with new Saticon tubes, the signal level should be adjusted by Iris Control to produce 225 mV highlight signal level in the Green Channel.

Next, observe the signal at the Green Video test point (E101) on the out proc, preferably viewing the step chart. Adjust the Green Gain to produce 1.4 Volts on the highest step of the test pattern. Be sure you do not increase the gain too far or there will be compression of this highest step.

In some cameras, compression starts at approximately 1.3 Volts.

The *Input proc* should then be put on an extender and the camera focused on the same step chart. Attach the scope to Pin 3 on the Input proc module connector. Push in and hold the white balance button while adjusting the Red Gain control to produce -2 Volts DC at this point.

Next, attach the scope to Pin 38 of the module connector, depress and hold the Auto White Balance control and adjust the Blue Gain for -2 Volts DC. This gain adjustment procedure will assure that the automatic white balance control has adequate range to accommodate a wide range of scene color temperatures.

The method of setting the Green Signal Level to a prescribed level is a more reliable field method of establishing the proper operating signal levels than the method utilizing a fixed test pattern illumination and assuming a certain test pattern reflectivity. Light meters are notoriously "out of calibration" and test pattern reflectivity can vary considerably.

### Beam Setting

The iris should then be adjusted to produce exactly 4 times the originally measured green signal level. The green beam control should be adjusted slowly in the downward direction to just handle the peak highlight and *no more*. The beam controls are on the deflection board of the camera.

With *no change* in the iris setting, the test cable should be plugged directly into the blue and red pre-amp coaxial cables in turn and the red and blue beam currents adjusted in exactly the same manner.

The adjustment of 4:1 beam reserve will also enable the TK-76 or TK-760 equipped with Saticon tubes to handle difficult scenes where a bright background must be overexposed to bring out the foreground objects, such as scenes shot against the sky or a sunlit wall.

Reset the lens iris to produce the original signal level measured in the green channel before doing any other adjustments.

### Focus and Registration

At this point, the beam focus, optical focus, tracking and registration adjustments should be performed according to the instruction manual. When performing electrical focus, the sharpest picture will occur when you focus for the best balance between horizontal and vertical resolution. This can be checked very conveniently utilizing the RCA P200 8" x 10" transparency test pattern (available from RCA EO&D, New Holland Ave., Lancaster, PA 17604).

Next, you're ready for the final camera balance and set-up procedures.

### Shading and Black Balance Adjustments

With the camera capped and a 10:1 scope probe, monitor the appropriate test point on the output proc. board. These are little pins sticking out from the side of the board. Use the scope viewing the horizontal trace and adjust the respective black balance control until the signal during scan time is equal to the level during retrace. This is done on all three channels: (red = test point E1; green = test point E101; blue = test point E201). This adjustment offsets the black level shift introduced by the bias light and assures that the blacks of the picture operate at the proper level at the input of the gamma correction amplifier. (Fig. 6).

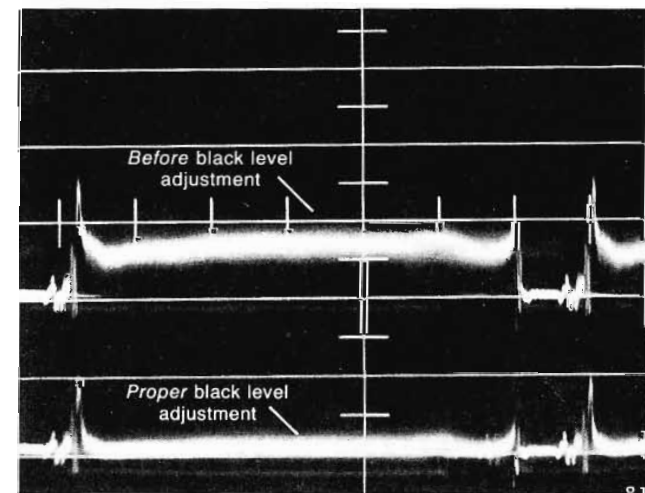

Fig. 6. Black level adjustment by means of black balance control.

With the scope probe at the same points, adjust the H and V SAW of the corresponding channel for the flattest signal. It is advisable to view the vertical rate for V SAW adjustments and the horizontal rate for the H SAW adjustment to assure best overall flatness. If the horizontal trace is bowed, Model "B" cameras only have a parabola shading control. To adjust this, you put the input proc. on an extender and adjust the controls (R25, R125 and R225)

for flattest signal.

Readjust the *green* black level balance monitoring test point E101, after shading adjustments are completed. Check proper adjustment level by switching on and off the *high sens.* switch on the left side of the camera. Adjust the black balance control so that the trace does not shift position as the switch position is changed. Final complete black level balance on the other channels will be performed later.

#### Flare Adjustments Are Made Next

Put an appropriate flare test pattern in front of the camera. A closed white carton with a hole equal to 10% of the area produces the best results. This produces a "true black." Reflective black "patches" usually produce several % reflection and result in over correction of flare. Focus and zoom the lens so that the black square occupies 10% of the picture and open the iris so the highlights are at 100% or 1.4 volts at the output proc. test points.

Cap the lens and observe the scan trace on the scope (D.C. amplifier setting) at the green channel test point (E101). Open the lens and adjust the green flare control (on input proc.) until the black hole signal lies on the capped signal level of the scope. Repeat for red (E1) and blue (E201) channels. Figures 7 and 8.

Final black balance and flare adjustments are made by monitoring the composite camera output signal on an oscilloscope using increased gain in both vertical and horizontal directions to stretch the display for most precise adjustment.

Cap the camera and adjust the R & B black balance controls for zero sub-carrier. Check balance with the switch thrown to "High Sens." If unbalance, favor balance adjusted while on high sens., or make a reasonable compromise.

Open the lens and focus on the "flare test" pattern. Adjust the blue and red flare controls for a minimum sub-carrier on the black hole signal.

Now, you're finished with all of the tube related controls. Gain balance and automatic control circuitry is then adjusted according to the instruction manual.

#### Operational Hints

The Saticon tube should not be exposed to a scene when the camera is turned off, otherwise a temporary image burn may result. The fastest way to erase such a burn is to point the camera at a bright flat white card covering the entire area, open the lens iris fully, defocus optically and turn off the camera for an hour or so.

Most Saticon tubes operate properly at the 50 volt target setting. If a temporary operational image burn should develop on long stationary exposure during use, a slight adjustment of the target voltage should correct this problem. If the retained image is negative, the target voltage should be increased 2 or 3 volt increments. If positive, this indicates that the target voltage should be reduced a few volts. If the target voltage is reduced more than 2 volts, the beam setting should be readjusted since altering the "target" voltage also alters the gun bias setting. Maximum optimum target voltage may be as high as 50 volts or as low as 40 volts.

#### The End Results

With the TK-76 or TK-760 equipped with Saticon tubes and properly set-up and adjusted, you can be confident that your camera can out-perform any 18mm Plumbicon-equipped camera in resolution and picture fidelity. The camera will handle high contrast scenes with little flare, and give the large studio cameras a "run for their money". Lag and sensitivity will be fully competitive and long life and reliability are assured. □

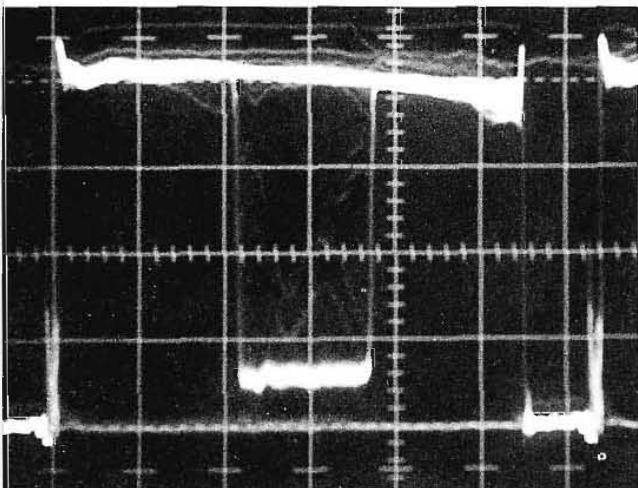

Fig. 7. Signal before flare correction. (Horizontal rate).

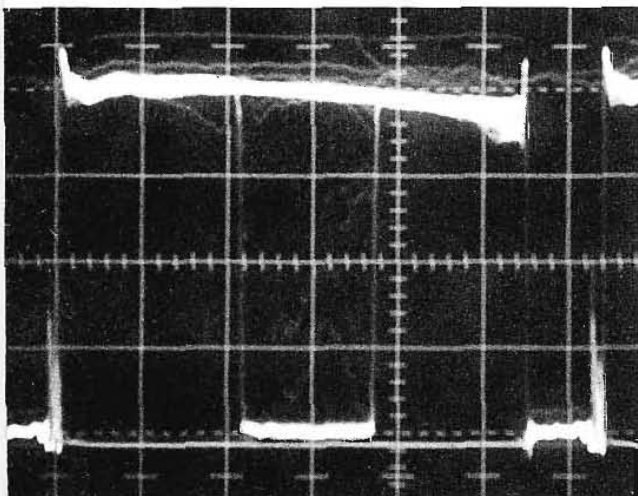

Fig. 8. Signal after proper flare correction. (Horizontal rate).

## Modifications Needed for TK-76A Cameras

The TK-76B and TK-760 cameras are designed with all of the necessary voltages and controls to operate Saticon tubes.

The TK-76A cameras do require some changes to operate the BC4390 Saticon tubes.

The BC4390 has the same specified range of  $G_1$  voltage required to cut off the beam as the Plumbicons. The low lag design of the Saticon gun results in tubes that operate at the more negative end of this voltage range. In some instances, the  $G_1$  voltage range provided in the TK-76A camera is insufficient to allow proper beam control of a BC4390 Saticon tube. It is recommended that you change the power transformer to provide this additional  $G_1$  voltage.

T1, should be Drawing No. 3416364-4 (RCA Stock No. 439171) instead of Drawing No. 3416364-3 (RCA Stock No. 435056). Transformer substitution may be made on a wire-for-wire (same color) basis. This effectively converts the module to a Power B unit.

With the new transformer installed, set the VOLT ADJ., R26, (formerly +650V control on the front panel for -12 volts (at TP-4). Other voltage will now be as indicated except that -125 volts will -140 volts and +270 volts will be +220 volts. This power supply change requires an additional change in the viewfinder.

Before applying power to the Viewfinder, be sure that the Viewfinder circuit includes

R20, a 68 K ohm resistor which provides protection against damage to the kinescope and capacitors. R20 (68 K ohm, 5%, 1/8W) should be located between board terminal "C" and the Brightness control. To add the resistor, cut the trace between the module board terminal "C" and R10-1, the Brightness control. Substitute R29 for the cut trace on the underside of the board. Refer to the schematic diagrams in the Viewfinder module books, IB-32995-1 or IB-32995-2.

One more circuit change is desirable. Saticon pickup tubes have a different target ring dimension. Therefore, the *Overscan-Normal* ratio should be revised so that when green height and width are adjusted for target corners to just show on *Overscan* in the color output signal, (*Overscan-Normal* switch in *Overscan*) the correct image size will result when the switch is in the *Normal* scan position.

To determine the proper changes on the **Deflection Module**, the module itself must be examined for the following, since there are several modifications of this module existing in cameras. **Your camera manual may not have the same resistor values on the deflection board** as indicated on the circuit diagram.

	Stock No.
If R57 is 7150 ohms, change R164 to 90.9 K ohms .....	436850
If R57 is 6340 ohms, change R164 to 76.8 K ohms .....	431933
If R58 is 7150 ohms, change R164 to 90.9 K ohms .....	436850
If R58 is 6190 ohms, change R163 to 75 K ohms .....	428746

These are special 1/4 watt 1% metal film resistors.

We challenge you to find a one-inch VTR as advanced as the TR-800.

TR-800 puts you in control like never before with unrivaled microprocessor implementation. And with astonishing speed, versatility and ease of operation. It's packed with innovative features, complete monitoring, and three levels of editing capabilities. It's equally at home in a van, rack, T-cart or console.

All electronics are readily accessible through a drop-down control panel or swing-out doors. Even while you're in operation.

We've met your challenge for a better VTR system. Now we challenge you to pit the TR-800 against any other one-inch VTR.

RCA Broadcast Systems, Building 2-2, Camden, NJ 08102.

# OUR ONE-INCH CHALLENGE.



